

SZ10-ZN/EN-A06

CREATOR PRO / 金刚狼

Quick Start Guide

≡ 快速启动指南 ≡

中文P19

 **WARNING**
注意事项

-
1. Do not remove the wrapping around the nozzle.
 2. Hot! Avoid touching the heating nozzle in operation.
 3. Moving parts in printer may cause injury. Do not wear gloves or other sources of entanglement in operation.
1. 切勿去除包裹在喷嘴处的耐高温材料。
 2. 高温危险！打印机喷嘴在工作时会被加热，操作时请避免接触！
 3. 可动部件可能会造成卷入挤压和切割伤害。操作机器时请不要配带手套或缠绕物。
-

Unpacking



1. Open box and remove top foam piece.



2. The foam should contain: two filament guide tubes, one SD card, two pieces of build tape, one Flashforge leveling card, one After-sales service, one Quick Start Guide and one User Guide.



3. Firmly grasp the two sides handles of Flashforge Creator Pro. Lift it out from the carton and place it on a stable surface.



4. Remove the packing bag. And then remove the tape and plastic wrap for protecting the front door.

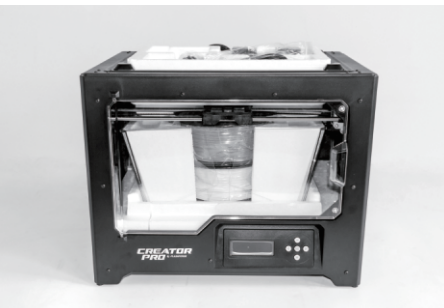

5. The Flashforge Creator Pro and its accessories shall be displayed in front of you.



6. Take the dual extruder out and place the extruder carefully because the extruder cable bunch is short.



7. Remove the foam container. It should contain: a power cable, an USB cable, two spool holders, a tool bag and an extruder's accessory kit.

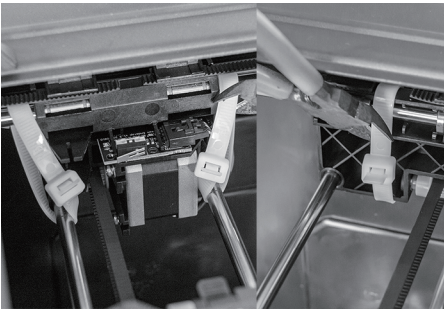
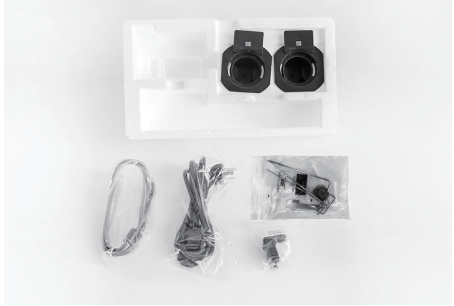

8. Shear three ties off on both sides of X-axis guide rod.



9. Slide the X-axis Rods to the very back.

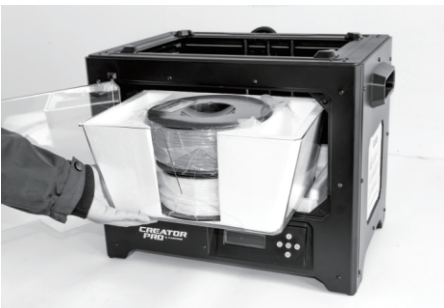

10. Open the door, remove top lid of the printer, take filament out of the lid.

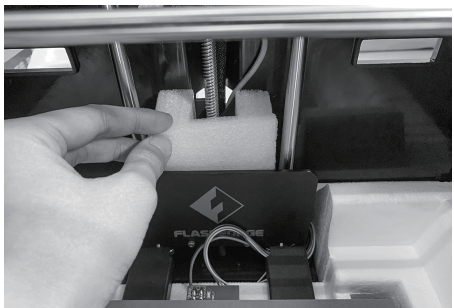

11. Find plastic board sealed with "Flashforge" at the back of build plate, take out the foam blocks at the back of plastic board.

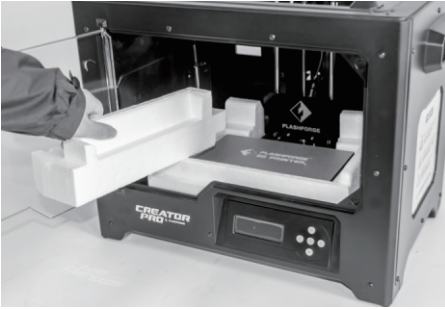

12. Remove side foam.



13. Take power cable out and plug it into power input.



14. Plug the other end of power cable into socket, turn on the power switch.

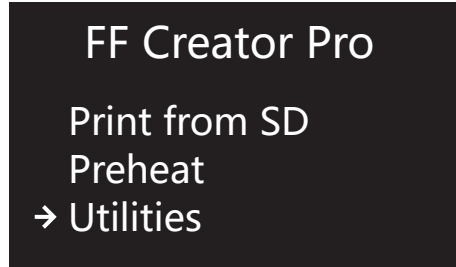

15. Operating on the LCD panel, press downwards arrow to choose [Utilities], tap [OK].

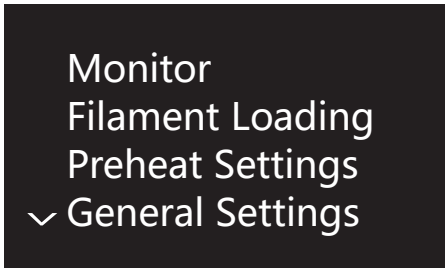

16. Press downwards arrow, enter the next page.



17. Press downwards arrow, enter the next page.



18. Choose [Jog Mode], tap [OK].

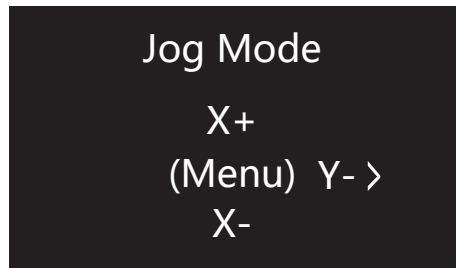

19. Tap rightwards arrow to the next page.

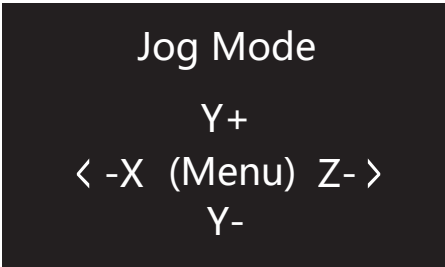

20. Tap rightwards arrow to the next page.

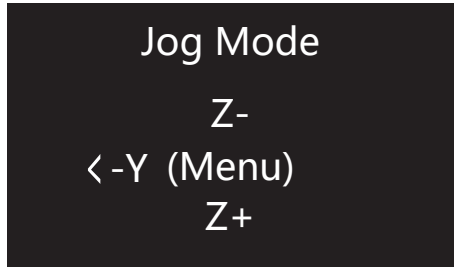

21. Press upwards arrow, the build plate goes up until it comes to the highest position, loose the button when the printer stops.

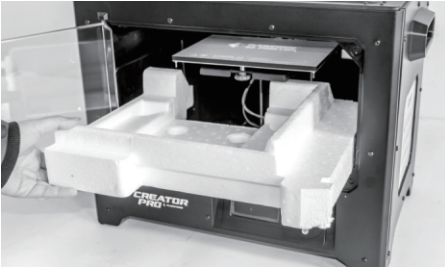

22. Remove foam under build plate.

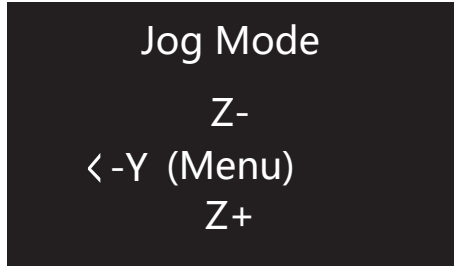

23. Press down arrow, loosen the button when the build plate descends to the middle of the printer. Tap [OK], go back.

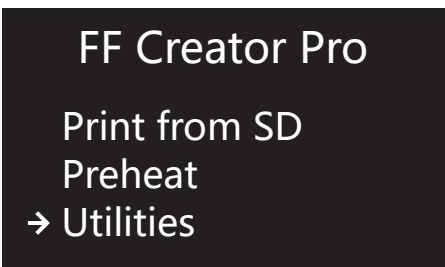

24. Tap [OK], go back, tap leftwards arrow twice, go back to the Home screen.



24. Unboxing completed! Recommended that you take good care of packing materials for further carrying and keeping.

Kit Contents

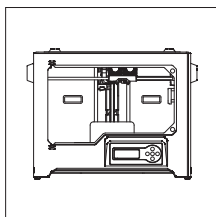

3D Printer

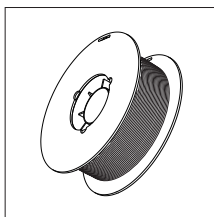

Filament Spool x 2

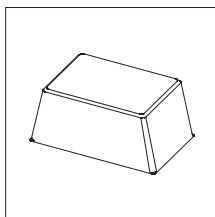

Lid



After-sales Service

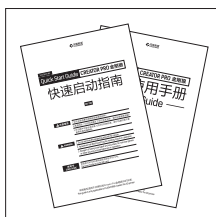

Quick Start Guide
User Guide

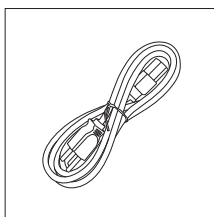

Power Cable

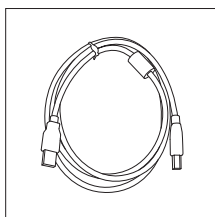

USB Cable

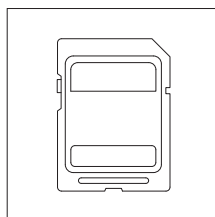

SD Card

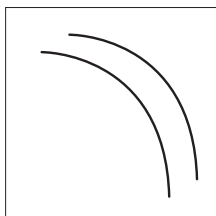

Filament Guidetube x2

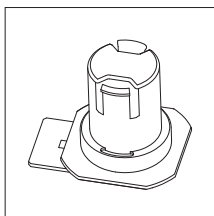

Spool Holder x 2

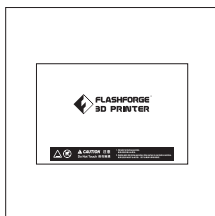

Build Tape x 2

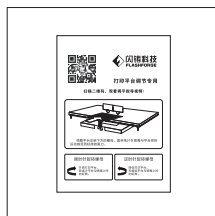

Leveling Card

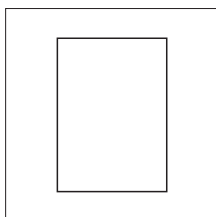

Tool Bag

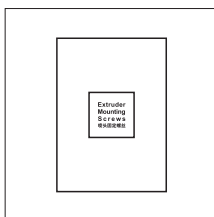

Extruder's
Accessory Kit

Tool bag:

Allen Wrench*2 / Knob / M3x8 Bolt*2 /
PTFE Tube*2 / Grease / Unclogging Pin Tool /
Wrench

Extruder's accessory:

M3x8 Bolt*2 / M3x6 Bolt / Turbofan Baffle

Getting to Know Your Creator Pro

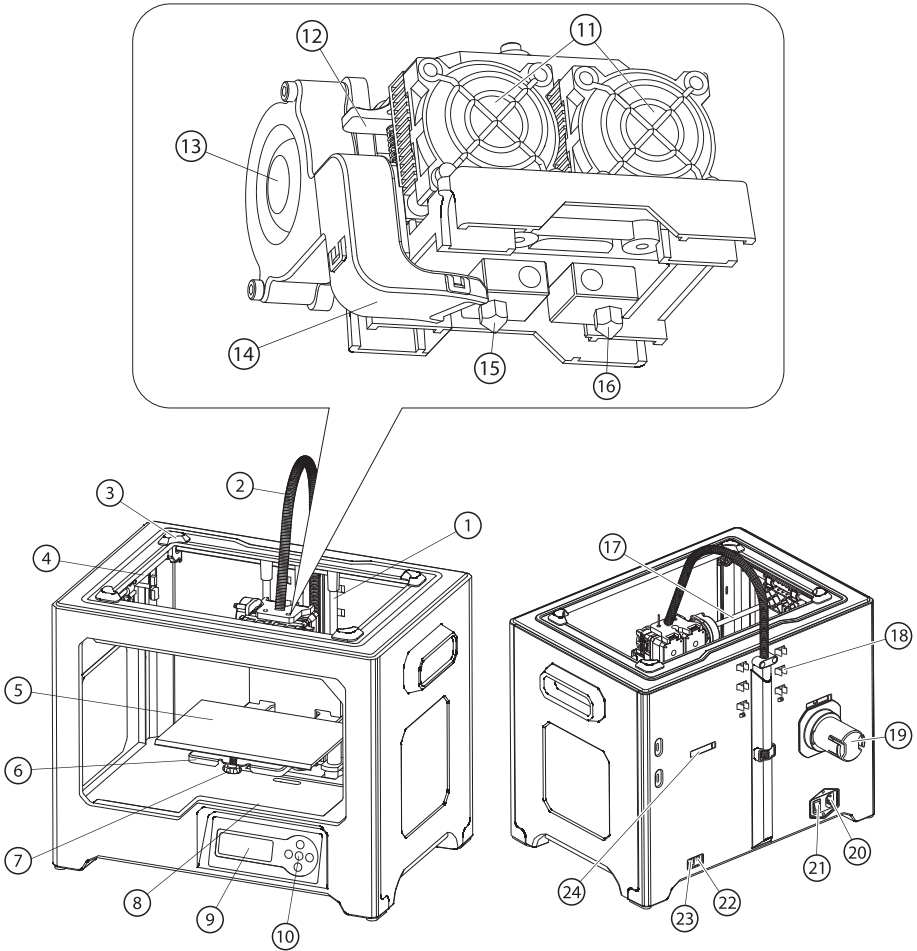

- | | | | |
|-----------------------|--------------------------------|------------------|---------------------|
| 1. Z-Axis Guide Rod | 2. Extruder Cable Bunch | 3. Lid Slot | 4. Y-Axis Guide Rod |
| 5. Build Plate | 6. Platform Support | 7. Knob | 8. SD Card Slot |
| 9. LCD Panel | 10. Buttons | 11. Cooling Fan | 12. Spring Presser |
| 13. Turbofan | 14. Turbofan Baffle | 15. Left Nozzle | 16. Right Nozzle |
| 17. X-Axis Guide Rod | 18. Filament Guide Tube Buckle | 19. Spool Holder | |
| 20. Power Input | 21. Power Switch | 22. Reset Button | 23. USB Cable Input |
| 24. Spool Holder Slot | | | |

Extruder Assembly

1. Place the dual extruder on the extruder seat.
2. Take the M2.5 Allen Wrench from the tool bag and two M3x8 bolts from the accessory kit.
3. Adjust the extruder location to align the bolt holes.
4. Secure the extruder onto the extruder seat by screwing the M3x8 bolts in.

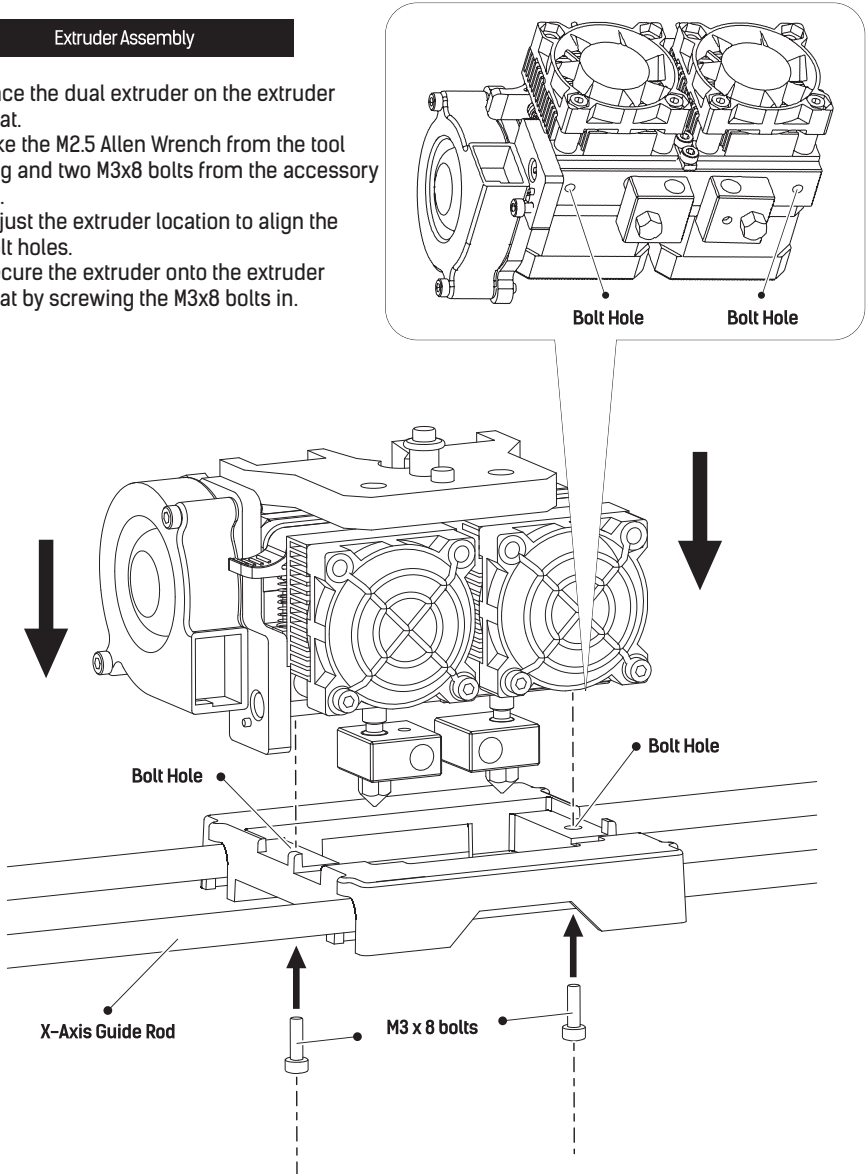

Turbofan Baffle Assembly

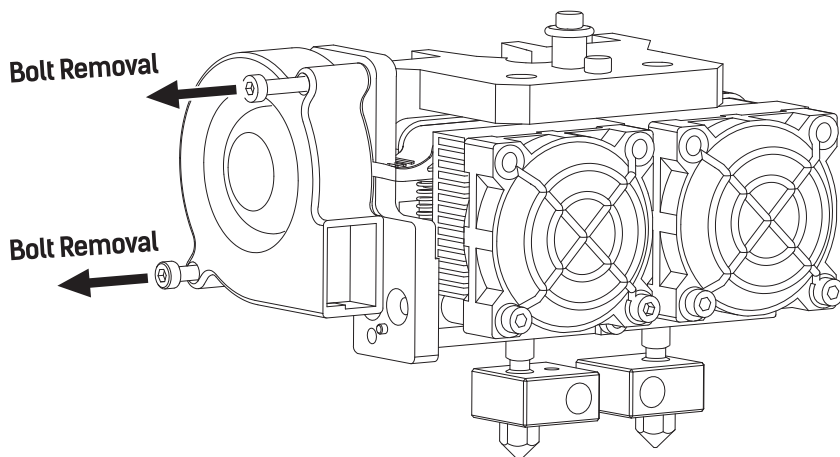

1. Use the M2.5 Allen Wrench to remove two turbofan bolts.

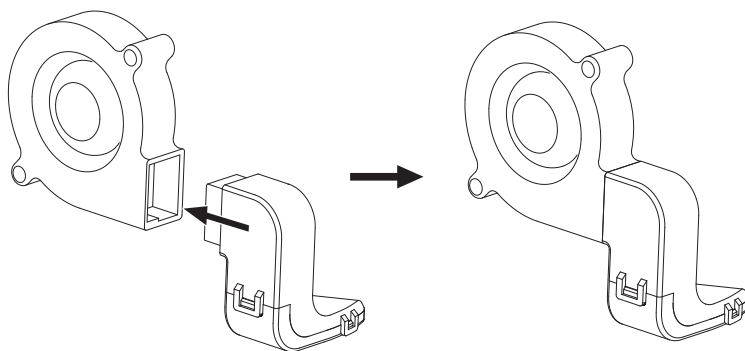

2. Take the turbofan baffle from the extruder's accessory kit.

3. Install the turbofan baffle to the turbofan.

Turbofan Seat •

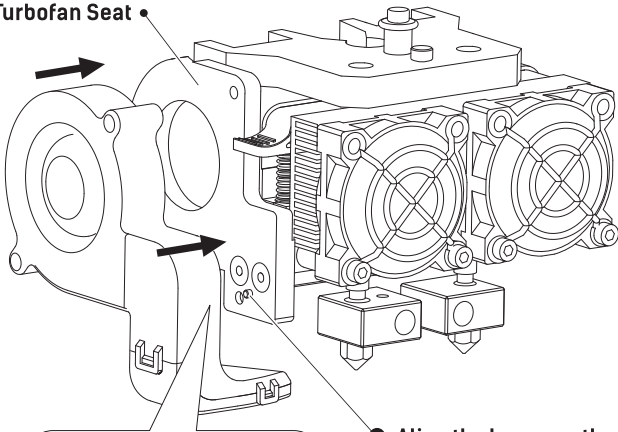

● **Align the bump on the turbofan seat to the hole in turbofan sub-assembly.**

1. Place the turbofan sub-assembly besides the turbofan seat.
2. Insert the bump on the turbofan seat to the turbofan sub-assembly.
3. Screw the two bolts in.
4. Take a M3 x 6 bolt from the extruder's accessory kit and complete installation according to the instruction below.

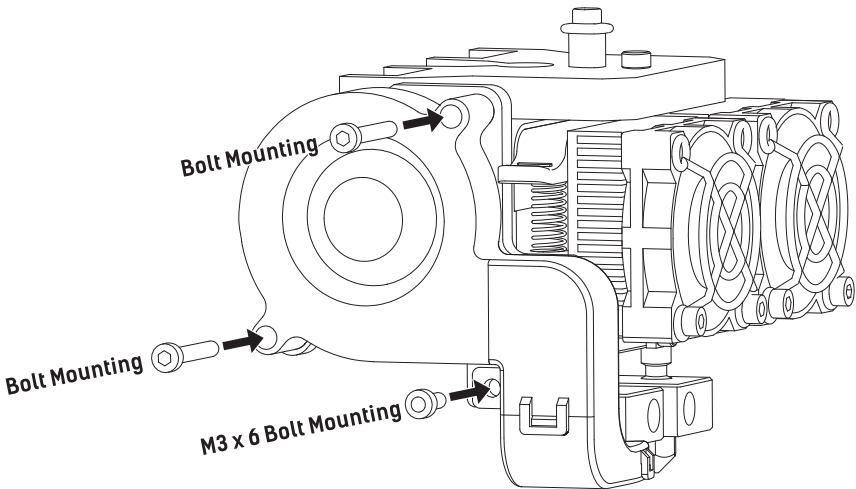

Filament Guide Tube and Filament Installation

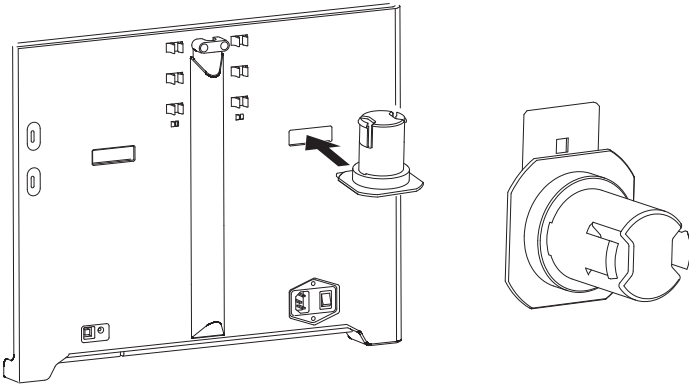

1. To install a spool holder, level it and insert the end into the corresponding opening.

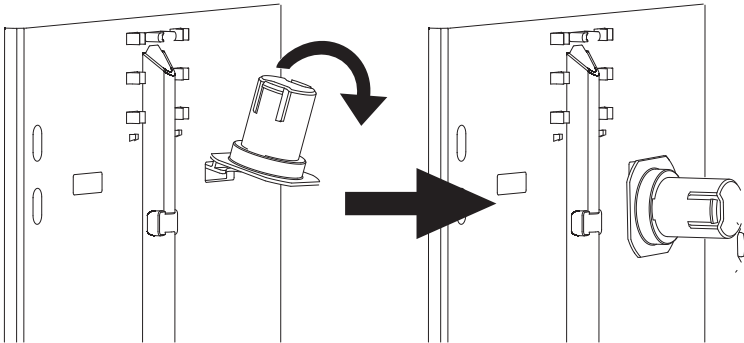

2. Turn down the spool holder to make the holder bottom cleave to the printer back.

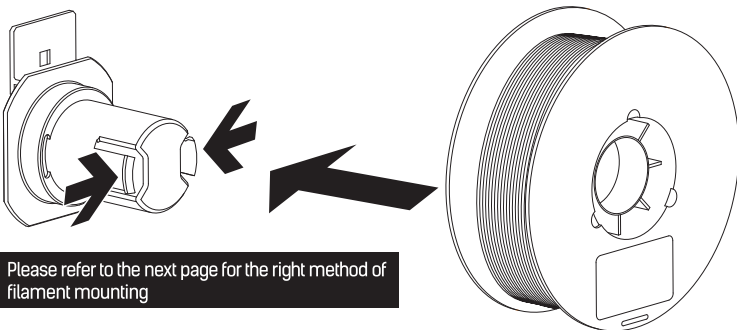

Please refer to the next page for the right method of filament mounting

3. Take filament out and remove vacuum packing, squeeze both sides on the top of spool holder and mount filament spool to the holder.

Filament installation tips

The filament spool must be oriented correctly (see below).

Correct Installation

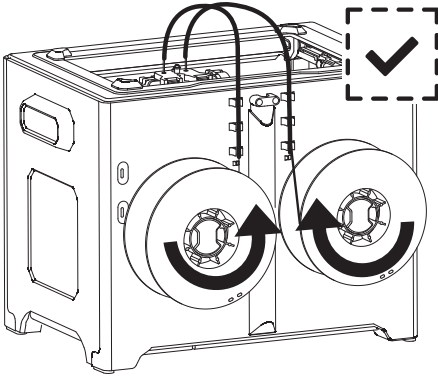

Wrong Installation

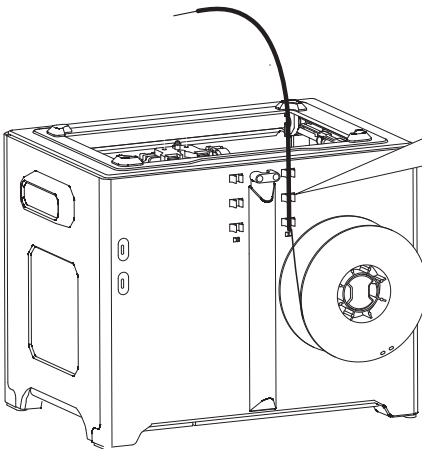
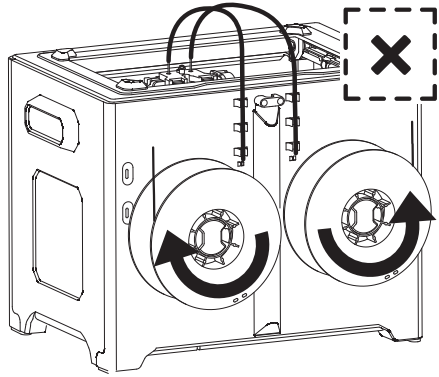

Filament
Guidetube
Buckle

Limited seat

4. Install PLA filament on the right side of the printer, and put filament through filament guidetube.

5. Lock filament guide tube into fixed buckles, and guidetube bottom should not be over limited seat.

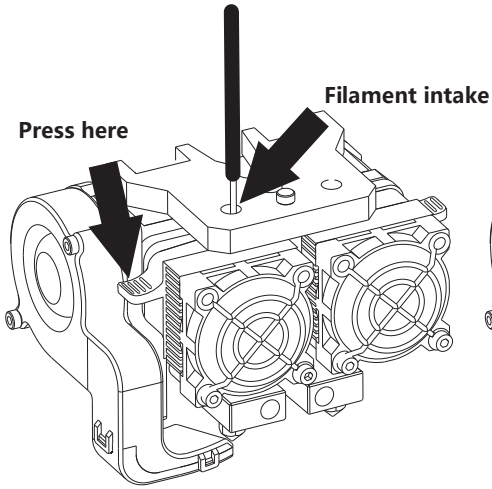

6. After filament guidetube fixation completed, press the left spring presser of extruder, put filament vertically into the left filament intake from the other end of filament guidetube.

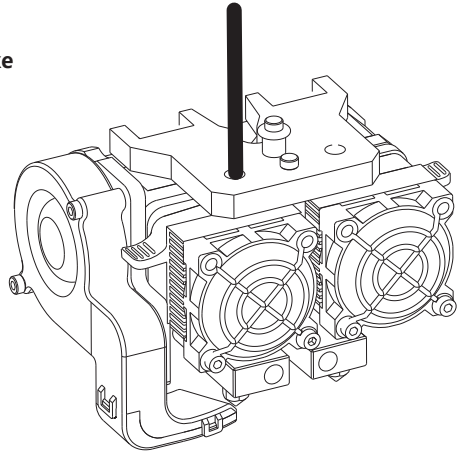

7. After filament going into filament intake, insert filament guidetube into filament intake to fix.

Before leveling, let's learn the function of knobs.

How to use the knobs

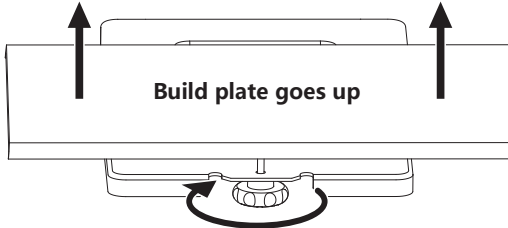

Rotate knob clockwise

Raise the build plate to reduce the distance between the nozzle and build plate.

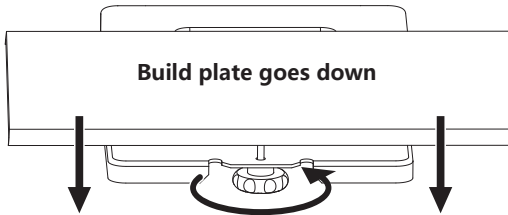

Rotate knob anticlockwise

Lower the build plate to increase the distance between the nozzle and build plate.

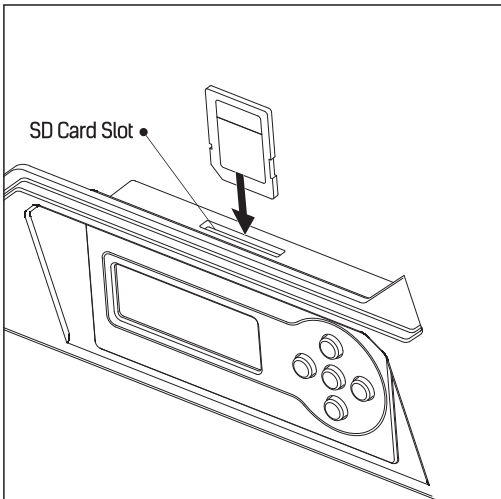

1. Insert the SD card into the SD card slot.

FF Creator Pro
→ Print from SD
Preheat
Utilities

▶ FlashPrint
→ ▶ PlateLeveling.x3g
▶ Test File
▶ Unpacking Video

2. Choose [Print from SD], tap [OK]. Choose [PlateLeveling.x3g], tap [OK] to leveling process.

Find the 3 knobs on the bottom of the platform and tighten four or five turns.

I'm going to move the extruder to various positions for adjustment.

In each position, we will need to adjust 2 knobs at the same time.

Nozzles are at the right height when you can just slide a sheet of paper

between the nozzle and the platform
Grab a sheet of paper to assist us.

Please wait.

3. After leveling starts, there would be a prompt on the LCD panel. Tap [OK], turn the page. After prompt is over, extruder starts to move and stops above leveling knobs at the front build plate.

Attention: Leveling would affect print effect directly, if print result is unsatisfactory, please do leveling again.

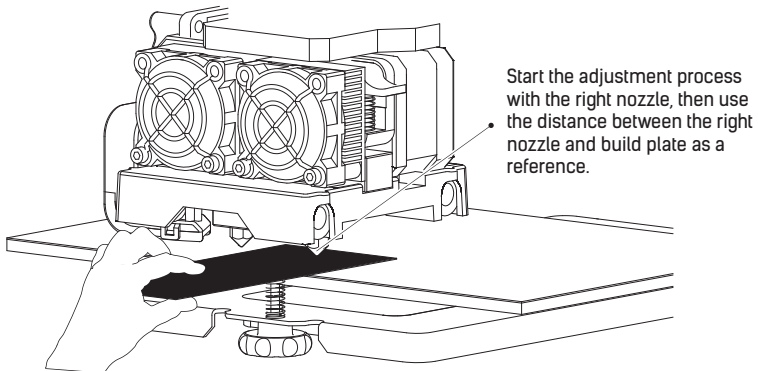

4. Take leveling card out, on the basis of right side extruder, put leveling card between right extruder and build plate. Slide leveling card back and forth and adjust knobs in the meantime.
- If you can move leveling card easily, please rotate knobs clockwise to reduce the distance between build plate and nozzle. Otherwise, rotate knobs anticlockwise to increase the distance between build plate and nozzle.
 - If you feel slight friction when moving leveling card, the distance between extruder and leveling card is proper, thus adjustment completed.
5. After the first leveling point completed, tap [OK]. The extruder will move to the second leveling point. Adopt same method to adjust. After three leveling points completed all, leveling completed. Tap [Ok] to end leveling process, press leftwards arrow to go back to home screen.
6. Press build plate slowly to the middle of the printer.

FF Creator Pro

Print from SD
Preheat
→ Utilities

1. Choose [Utilities], and then tap [OK].

Monitor

→ Filament Loading
Preheat Settings
General Settings

2. Choose [Filament Loading], and then tap [OK].

Unload right
Load right
Unload left
→ Load left

3. Choose [Load left], and then tap [OK].

Heating: ■■■■
Extruder: 26/230C

Press left to cancel

4. Extruder starts to heat.

Begin loading or unloading. Press the center button when finished.

5. Once heated, filament will be drawn through the extruder. Continue extruding until the extruder provides a steady flow of filament. Tap [OK], go back. Tap leftwards arrow twice, go back to the home screen.

Attention: If extruder can not unload in a long time, please check if you have inserted filament into the bottom of extruder.

Suggestions

1. Ensure that the build plate has been leveled before printing.
2. Ensure that the filament has been loaded in an appropriate approach.
3. Load the filament for a while to extrude all the melted filament you printed last time out of the extruder.
4. Print with ABS filament, install top cover, close the front door. Print with PLA filament, remove top cover, open the front door.
5. Please clean extruder before printing.
6. Do not leave the printer unattended during operation.

FF Creator Pro

→ Print from SD Preheat Utilities

1. Choose [Print from SD], tap [OK].

- ▶ FlashPrint
PlateLeveling.x3g
- ▶ Quick Start Guide
- ▶ Test File

2. Choose [Test File], tap [OK].



- 40mmCUBE-Left-PLA
40mmCUBE-Right-PL
Hillbert-CUBE-PLA

3. Choose [40mmCUBE-Left-PLA.gx], tap [OK].

Heating: ■■■■

R Extruder: 15C

L Extruder: 15/200C

Platform: 14/ 50C

40mmCUBE-Left-PLA 0%

R Extruder: 26C

L Extruder: 200/200C

Platform: 50/ 50C

4. The extruder and the build plate starts to heat.
5. After completing preheat, the printer starts to print.

Unloading Filament

Please follow steps below if you need to unload filament in daily use.

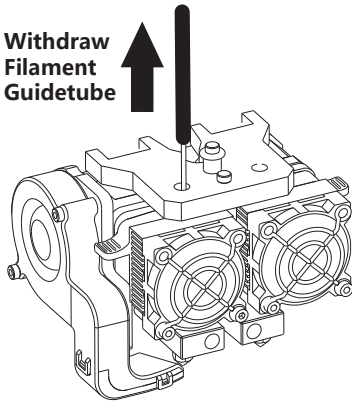

FF Creator Pro

Print from SD
Preheat
→ Utilities

1. Pull filament guide tube out of filament intake, leave filament 10cm to pull filament easily.
2. Choose [Utilities], tap [OK].

Monitor
→ Filament Loading
Preheat Settings
General Settings

Unload right
Load right
→ Unload left
Load left

3. Choose [Filament Loading], tap [OK].

4. Choose [Unload left], tap [OK].

Heating: ■■■
Extruder: 26/230C

Press left to cancel

5. Extruder starts to heat.

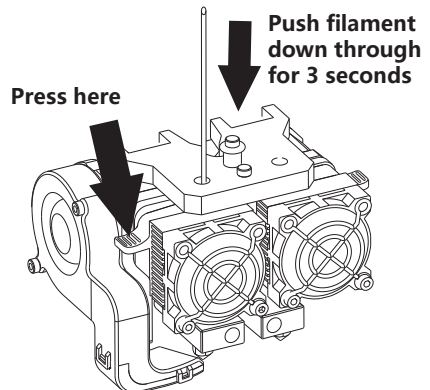

6. When heating to target temperature, press spring presser and push filament down through for 3 seconds until you see steady filament coming out from nozzle.

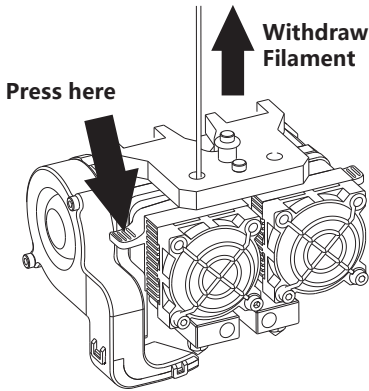

6. Then pull out vertically quickly and release spring presser.
Tap [OK], go back. Tap leftwards arrow twice, go back to the home screen.

Installation and Dismantlement

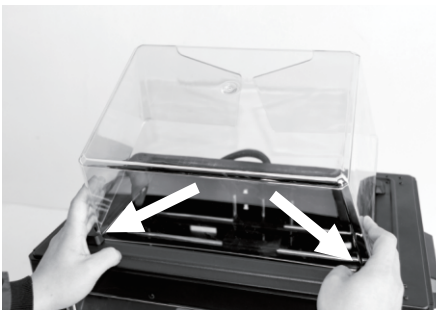
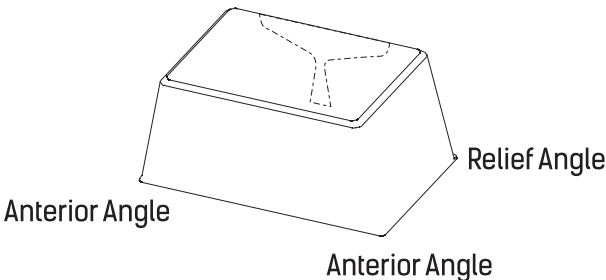

1. Place the two anterior angles of the lid into the corresponding front slots.

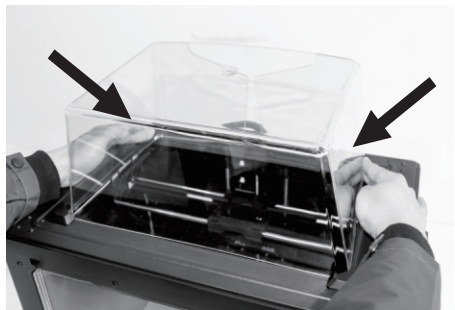

2. Slightly squeeze the two relief angles to place them into the corresponding rear slots.
To remove the lid, squeeze the relief angles to remove them from the slots.

开箱



1. 打开纸箱取出顶部泡沫。

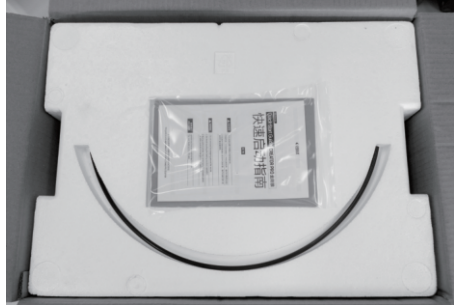

2. 在顶部泡沫中包含有两根导丝管、一张SD卡、两张平台贴纸、一张调平卡片、一份售后服务卡、一本用户使用手册和一本快速启动指南。



3. 抓住机身两侧的把手，将打印机从纸箱中提出。



4. 撕除胶带，去除设备包装塑料袋。随后撕去固定前门的胶带及包裹前门的薄膜。

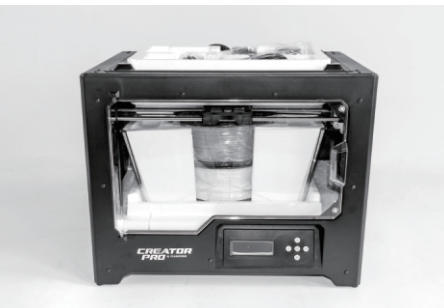

5. 移除塑料袋后，您可以看到打印机内部的包装以及配件，我们自上至下逐一解除包装，拿出配件。



6. 首先撕除蓝色胶带，将喷头从泡沫中取出，放置在台面上。连接喷头的线束较短，在摆放喷头时请注意。



7. 取出装有配件的泡沫盒，其中包含一根电源线、一根USB数据线、两个丝盘轴、一个工具包和一个喷头安装包。

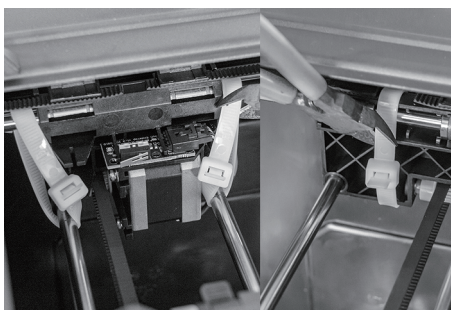
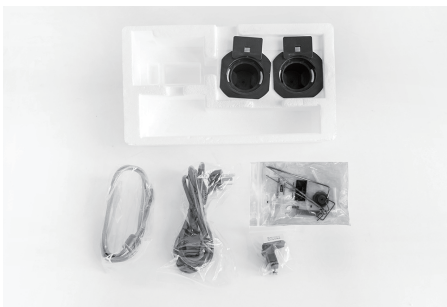

8. 剪断X轴导轨两侧的扎带，共三根。



9. 将X轴导轨向后滑动到打印机后方。



10. 打开前门，取出打印机上罩，然后取出上罩中的打印耗材。

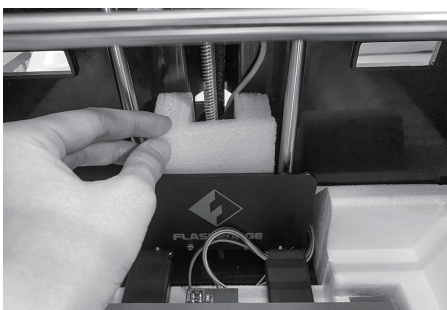

11. 在打印平台后方找到印有闪铸logo的塑料板，取出塑料板后方的泡沫块。

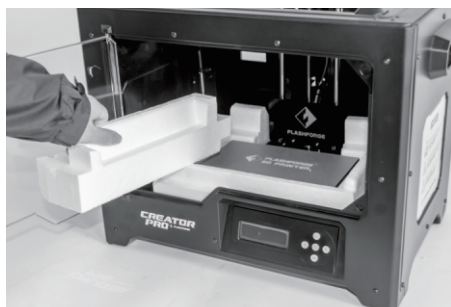

12. 取出底部左侧的泡沫。



13. 取出电源线，插入打印机背部的电源线接口。



14. 将电源线另一头插入插座，接通电源。然后打开电源线接口旁边的电源开关开机。

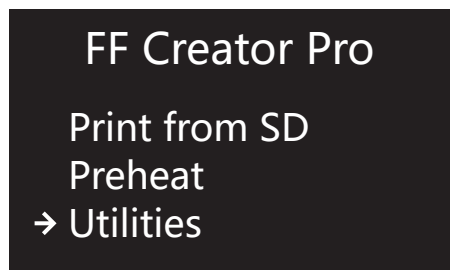

15. 使用按键对液晶屏进行操作。按向下的箭头选中 [Utilities]，按[OK]键。

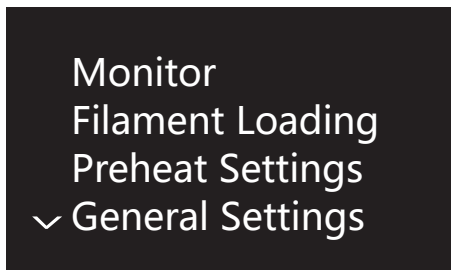

16. 继续按向下的箭头，进入下一页面。



17. 继续按向下的箭头，进入下一页面。



18. 选中[Jog Mode]，按[OK]键。

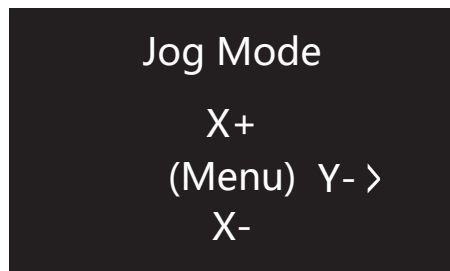

19. 按向右的箭头翻页。

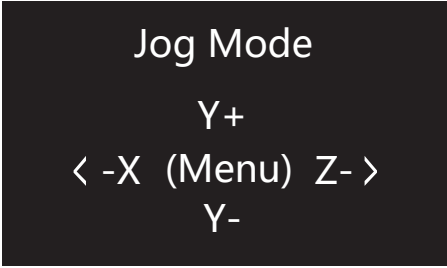

20. 按向右的箭头翻页。

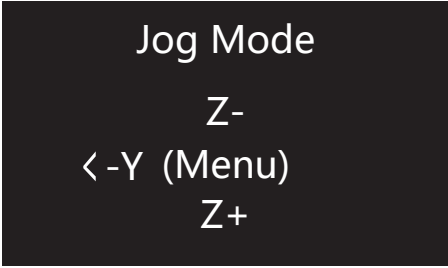

21. 按住向上的箭头，使打印平台上升。打印平台升到最高位置时会自动停止，停止后松开按键。

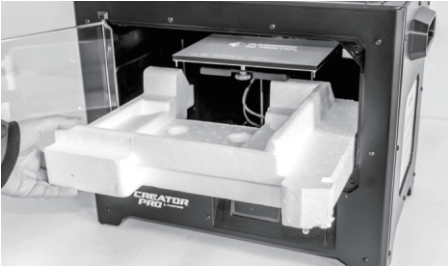

22. 取出打印平台下方的泡沫。

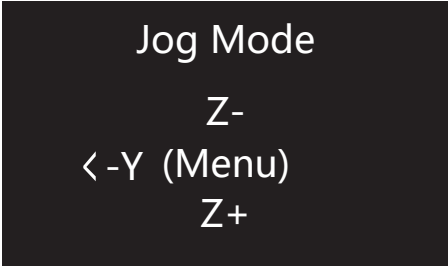

23. 按住向下的箭头，待打印平台下降到打印机中部后即可松开按键。

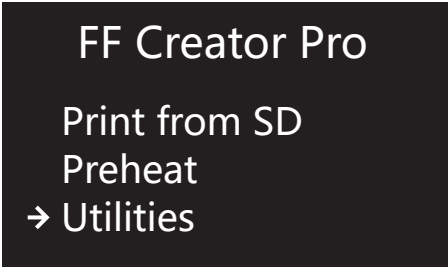

24. 按[OK]键返回上一级，之后按向左的箭头返回首界面。

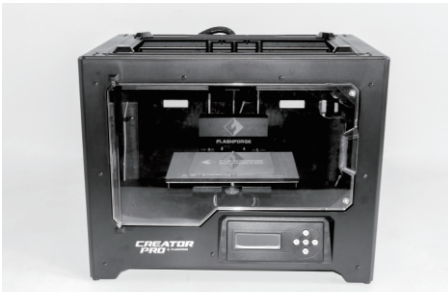

25. 开箱完成！建议您保管好这些包装材料，便于以后的搬运或保存。

装箱物品

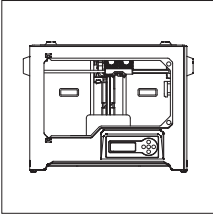

3D打印机

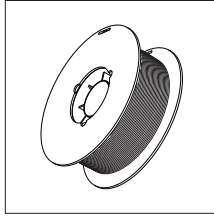

3D打印耗材 x 2

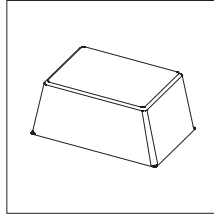

顶罩



售后服务卡



快速启动指南
用户使用手册

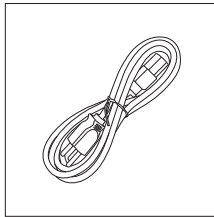

电源线

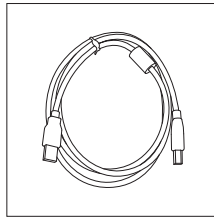

USB线

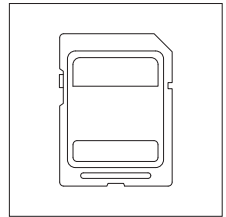

SD卡

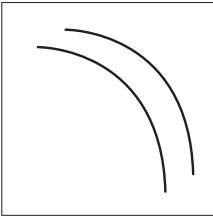

导丝管 x 2

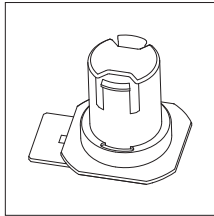

丝盘轴 x 2

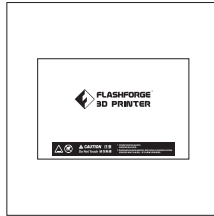

平台贴纸 x 2

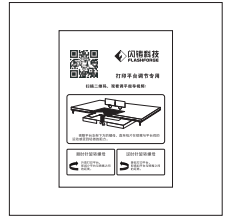

调平卡片

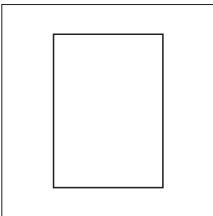

工具包

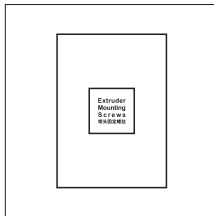

喷头安装包

工具包内含：

M 3*8规格螺丝两颗 / 2根聚四氟管 / 一枚手旋螺母
一把扳手 / 两把内六角扳手 / 一根通针 / 一袋润滑脂

喷头安装包内含：

M 3*8规格螺丝两颗 / M 3*6螺丝一颗 / 导风嘴部件

部件介绍

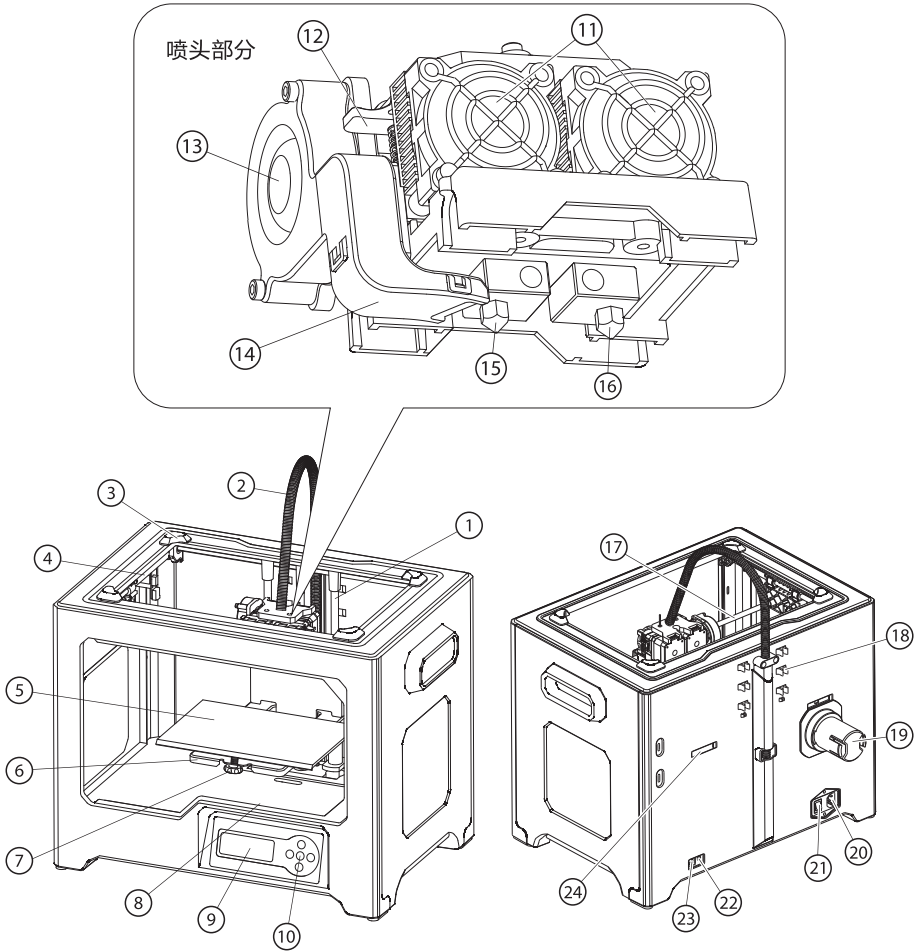

- | | | | | |
|------------|----------|--------------|-----------|-----------|
| 1. Z轴导轨 | 2. 喷头线束 | 3. 顶罩卡槽(四个角) | 4. Y轴导轨 | 5. 打印平台 |
| 6. 平台支架 | 7. 调平螺母 | 8. SD卡插槽 | 9. 液晶屏 | 10. 按键 |
| 11. 喷头散热风扇 | 12. 进丝压板 | 13. 涡轮风扇 | 14. 导风嘴 | 15. 左喷头喷嘴 |
| 16. 右喷头喷嘴 | 17. X轴导轨 | 18. 导风管卡扣 | 19. 耗材丝盘轴 | 20. 电源线接口 |
| 21. 电源开关 | 22. 复位键 | 23. USB线接口 | 24. 丝盘轴插口 | |

1. 安装喷头

1. 如下图所示，将喷头放置于喷头支架(中塑件)上。
2. 从工具包中取出最大号的内六角扳手(M2.5)；从喷头安装包中取出2颗M3 x 8螺丝(较长的两颗)。
3. 适当调整喷头位置，使喷头与喷头支架的螺丝孔对齐。
4. 用内六角扳手从喷头支架下方旋入螺丝固定喷头。

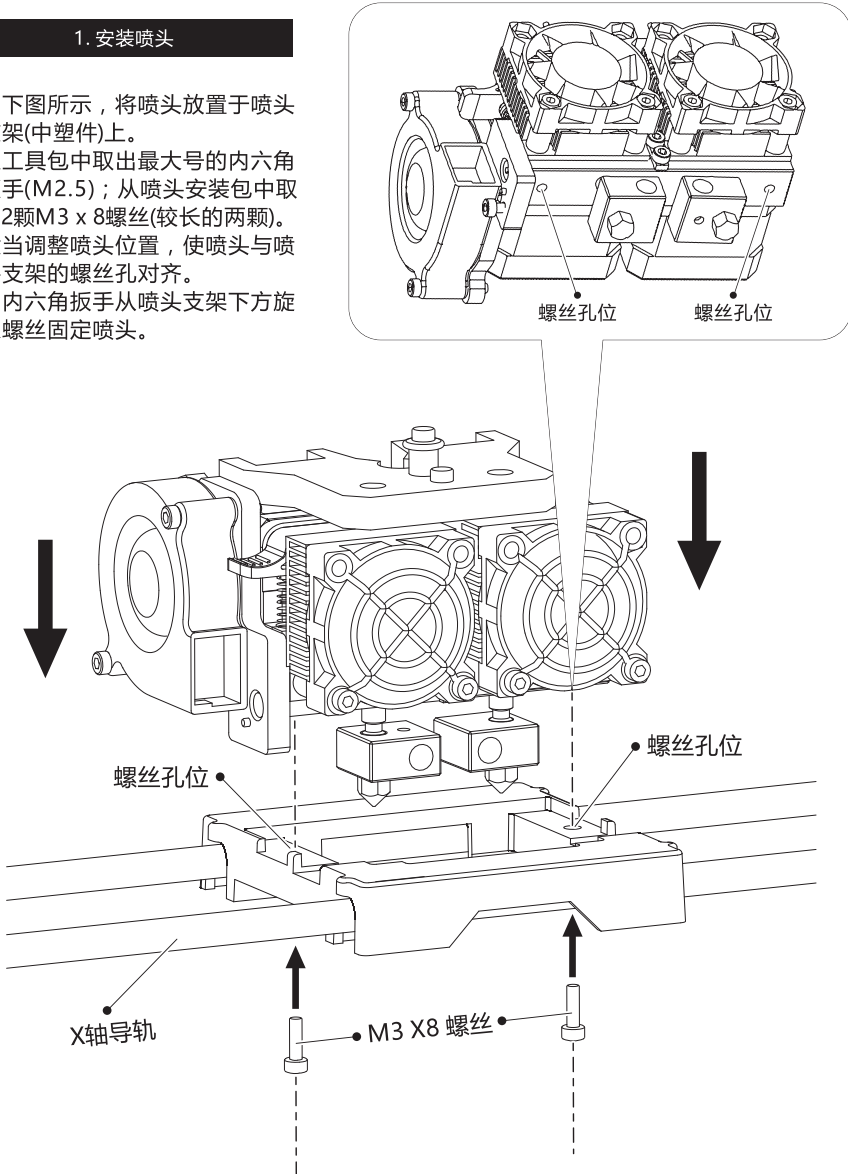

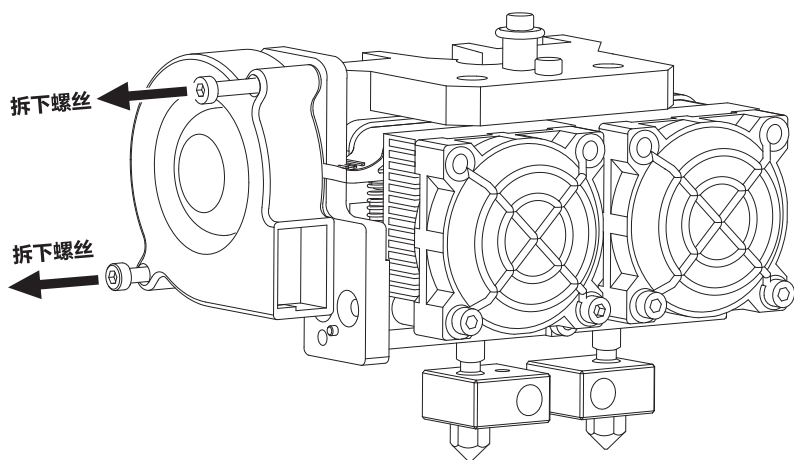

2. 安装导风嘴

注意：连接涡轮风扇的电线较短，拆卸及安装导风嘴时请注意。

1. 如上图所示，使用M2.5内六角扳手拆下固定涡轮风扇的两颗螺丝。
2. 从喷头安装包中取出导风嘴部件。如下图所示，将导风嘴部件装入涡轮风扇。

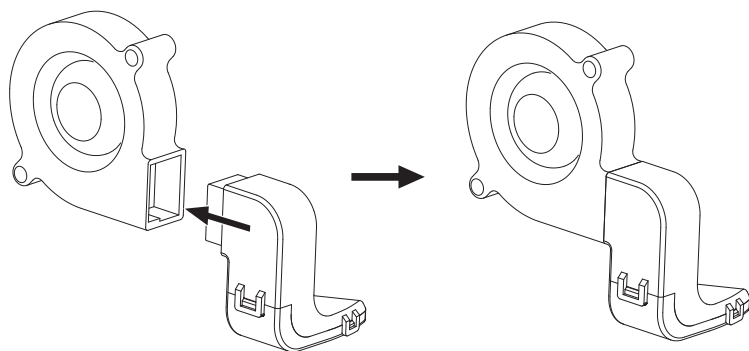

安装导风嘴

完整的涡轮风扇

涡轮风扇固定座

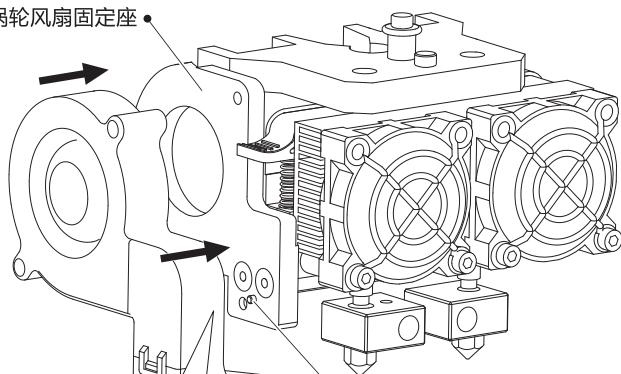

将涡轮风扇固定座上的突起对准导风嘴上对应的小孔

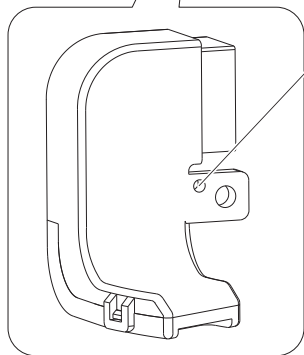

1. 将完整的涡轮风扇重新放置于喷头左侧，准备用螺丝固定。
2. 如左图所示，请确保涡轮风扇固定座上的突起对准导风嘴上的小孔。
3. 如下图所示，将先前拆下的2颗螺丝原样装回。
4. 从喷头安装包中取出M3 x 6螺丝(剩下的一颗)，装入图中所示位置。

到此喷头部分安装完成。

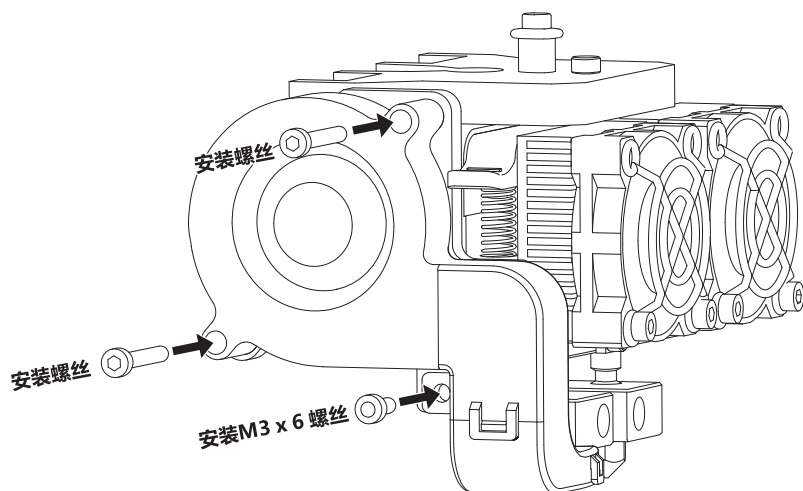

3. 安装耗材及导丝管

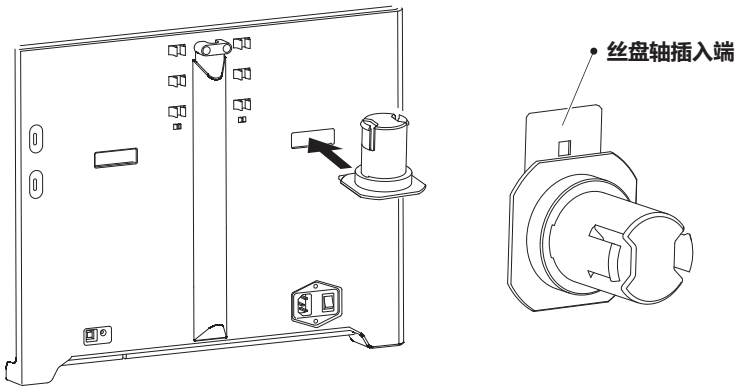

1. 将丝盘轴插入端插入打印机背部的丝盘轴插口中。

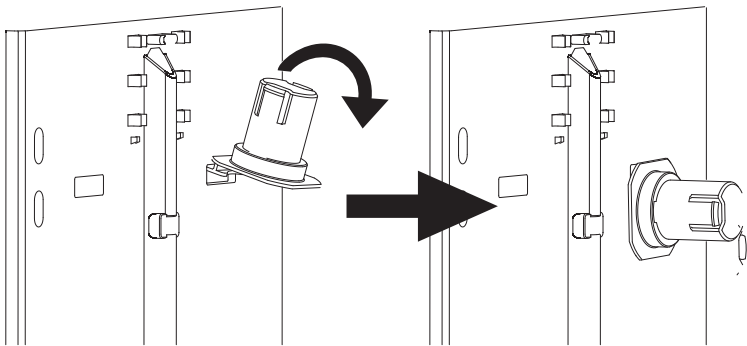

2. 丝盘轴插入丝盘轴插口后，让丝盘轴底部向下贴住打印机背部。

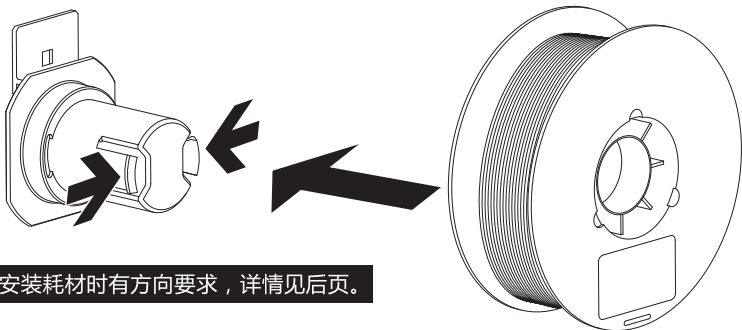

3. 取出耗材并去除真空包装，轻轻挤压丝盘轴顶端两侧，使耗材中间的丝盘轴孔套入丝盘轴。

耗材安装提示

安装耗材时请注意丝盘的安装方向。如下图所示，请保证耗材从内侧出丝。

安装正确：内侧出丝

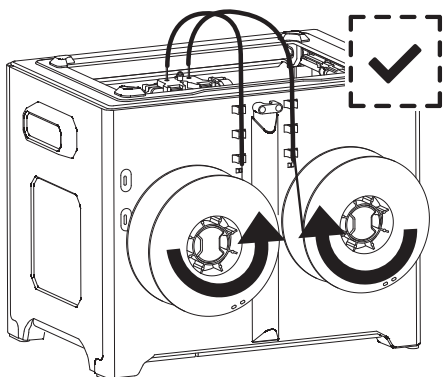

安装错误：外侧出丝

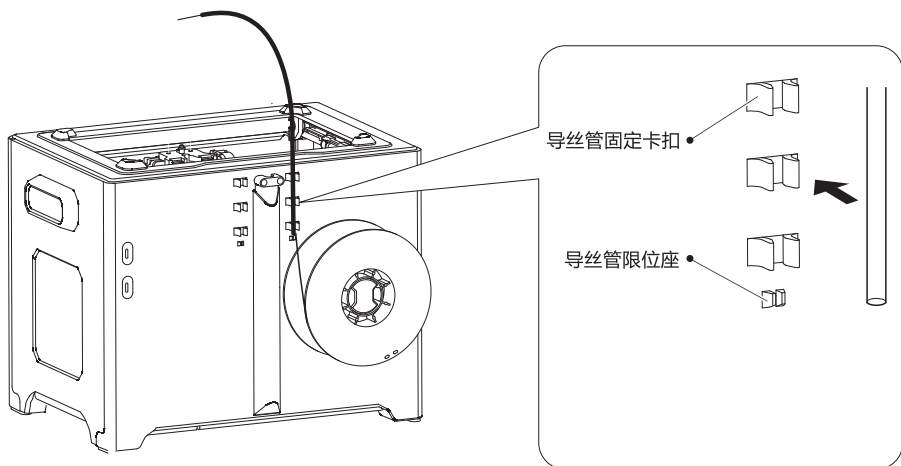
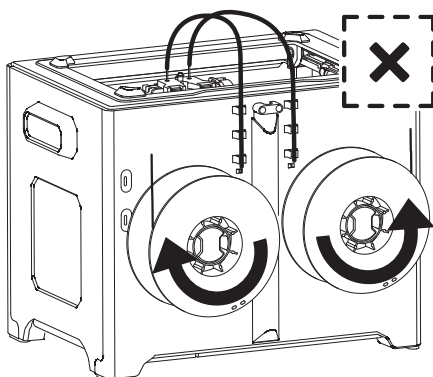

4. 将PLA耗材安装在打印机右侧，然后将耗材穿过导丝管，并从导丝管的另一头穿出。

5. 将导丝管卡入机身背部的导丝管固定卡扣中。导丝管下端不应当超过限位卡座。

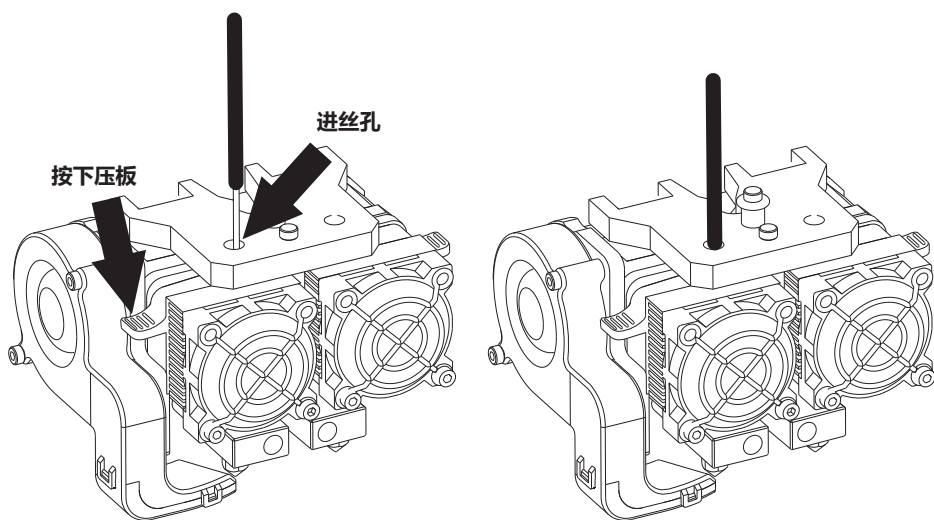

6. 导丝管固定完成后，按下左喷头一侧的压板，将从导丝管另一头穿出的耗材垂直插入喷头进丝孔中，直到耗材无法继续插入。

7. 耗材插入进丝孔后，再将导丝管插入喷头进丝孔固定。

调平

在调平开始前，让我们先了解一下调平螺母的作用。

如何通过调平螺母调节打印平台

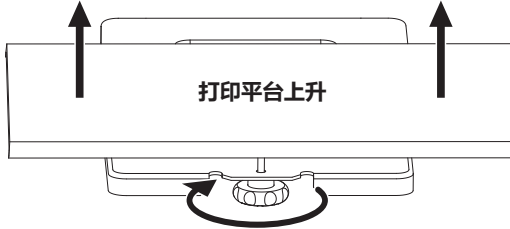

顺时针旋转螺母

打印平台上升，喷嘴与平台之间间距变小

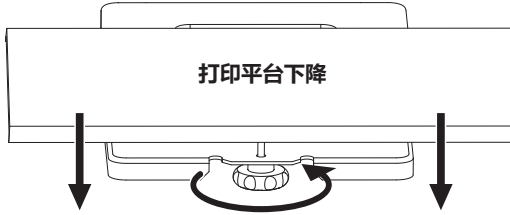

逆时针旋转螺母

打印平台下降，喷嘴与平台之间间距变大

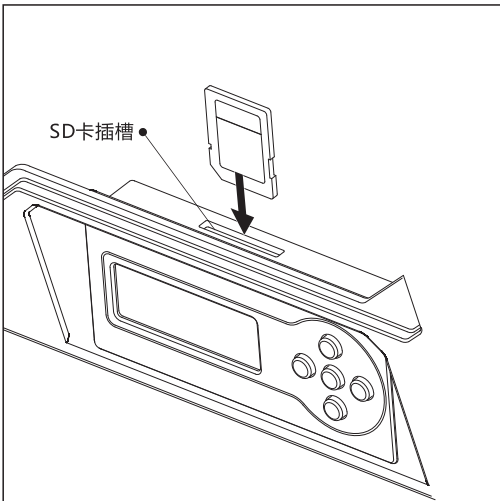

1. 取出SD卡，插入SD卡插槽中。
SD卡插槽位于打印机内侧，
液晶屏上方。

FF Creator Pro
→ Print from SD
Preheat
Utilities

▶ FlashPrint
→ ▶ PlateLeveling.x3g
▶ Test File
▶ Unpacking Video

2. 选中[Print from SD]，按[OK]键。选中[PlateLeveling.x3g]，按[OK]键开始运行调平程序。

Find the 3 knobs on the bottom of the platform and tighten four or five turns.

I'm going to move the extruder to various positions for adjustment.

In each position, we will need to adjust 2 knobs at the same time.

Nozzles are at the right height when you can just slide a sheet of paper

between the nozzle and the platform
Grab a sheet of paper to assist us.

Please wait.

3. 调平程序开始后，系统会在液晶屏上显示一段英文提示信息。按[OK]键查看下一页。提示信息结束后，喷头开始移动并停止在平台前端的调平螺母上方。

注意：调平效果会直接影响到打印效果，如果打印效果不理想，请再次对平台进行调平。

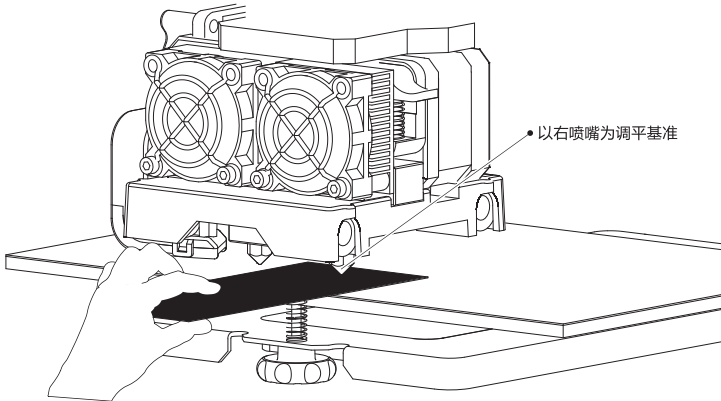

4. 取出调平卡片，以右侧喷嘴为基准，将调平卡片放入右喷嘴与打印平台之间。一手调节调平螺母，一手来回滑动调平卡片感受摩擦力。
- 若卡片可以轻松抽动则表示喷嘴与平台的间距过大，需要顺时针旋转下方的调平螺母来缩小平台与喷嘴的间距。
 - 若抽动卡片时阻力较大，表示喷嘴与平台的间距过小，需要逆时针旋转下方的调平螺母来增大平台与喷嘴的间距。
 - 若抽动卡片时感到有轻微的摩擦感，表明此时喷嘴与平台的间距比较合适，可以停止调节。
5. 第一个点调平完成后，按[OK]键，喷头会移动到第二个调平点上方。采用同样的方法对该点进行调节。以此类推，当三个调平点都调平完成后（三个调平螺母上方），调平完成，按[OK]键结束调平程序，按向左的箭头返回首界面。
6. 将打印平台缓缓压回打印机底部。

FF Creator Pro

Print from SD

Preheat

→ Utilities

1. 选中[Utilities], 按[OK]键。

Monitor

→ Filament Loading

Preheat Settings

General Settings

2. 选中[Filament Loading], 按[OK]键。

Unload right

Load right

Unload left

→ Load left

3. 四个选项从上到下分别是：右喷头退丝、右喷头进丝、左喷头退丝、左喷头进丝。选中[Load left], 按[OK]键。

Heating: ■■■■

Extruder: 26/230C

Press left to cancel

4. 左喷头开始加热。

Begin loading or unloading. Press the center button when finished.

5. 喷头加热到预定温度后开始进丝，看到喷嘴开始出丝时请勿立即停止进丝，直到耗材均匀出丝为止。按[OK]键返回上一界面，然后按向左的箭头两次返回首界面。

注意：若长时间喷头未出丝，请检查填充耗材时是否正确将耗材插入喷头底部。

首次打印

打印建议

1. 打印开始前请确保打印机已经经过调平；
2. 打印开始前确保耗材安装正确，没有打结或卡住；
3. 喷头内可能残留有少量耗材，请进丝一段时间，确保上一次打印的耗材已经全部挤出；
4. 使用ABS耗材打印时，请装上顶罩，关闭前门；使用PLA耗材打印时，请移除顶罩，打开前门；
5. 打印开始前请将喷头耗材清理干净；
6. 不可在长时间无人看守的情况下使用3D打印机；

FF Creator Pro

→ Print from SD
Preheat
Utilities

1. 选中[Print from SD]，按[OK]键。

▶ FlashPrint
PlateLeveling.x3g
▶ Quick Start Guide
→ ▶ Test File

2. 选中[Test File]，按[OK]键。



→ 40mmCUBE-Left-PLA
40mmCUBE-Right-PL
Hillbert-CUBE-PLA

3. 选择[40mmCUBE-Left-PLA.gx]，按[OK]键。

Heating: ■■■■
R Extruder: 15C
L Extruder: 15/200C
Platform: 14/ 50C

4. 打印机开始加热。

40mm_Box Left PLA 0%
R Extruder: 26C
L Extruder: 200/200C
Platform: 50/ 50C

5. 加热完成后，开始打印。

退丝操作

在日常使用中,如果需要更换耗材,建议按下列步骤操作。

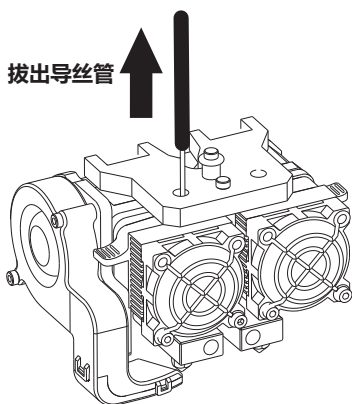

1. 拔出导丝管。

FF Creator Pro

Print from SD
Preheat
→ Utilities

2. 选中[Utilities],按[OK]键。

Monitor
→ Filament Loading
Preheat Settings
General Settings

3. 选中[Filament Loading],按[OK]键。

Unload right
Load right
→ Unload left
Load left

4. 按左喷头退丝举例。选中[Unload left],按[OK]键。

Heating: ■■■■
Extruder: 26/230C
Press left to cancel

5. 左喷头开始加热。

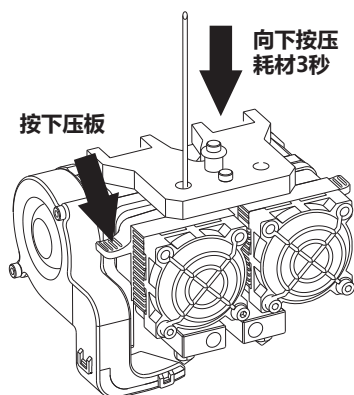

6. 喷头加热到预定温度后开始进丝,当喷头加热到预定温度后,按下喷头侧边的压板,同时向下按压耗材3秒,直到看到耗材从喷嘴处被挤出。

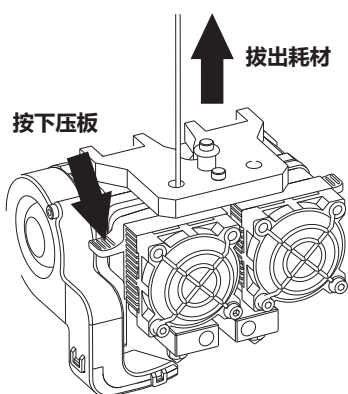

6. 快速垂直拔出耗材。按[OK]键返回上一级，然后按两次向左的箭头返回首界面。

附：顶罩的安装与拆卸

在日常使用中，如果需要更换耗材，请按下列步骤操作。

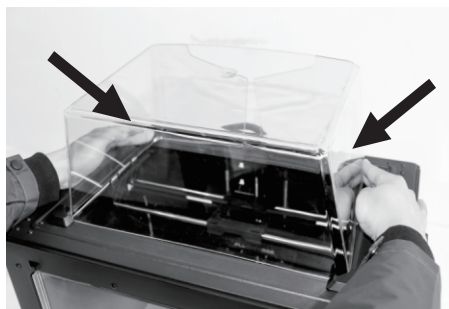
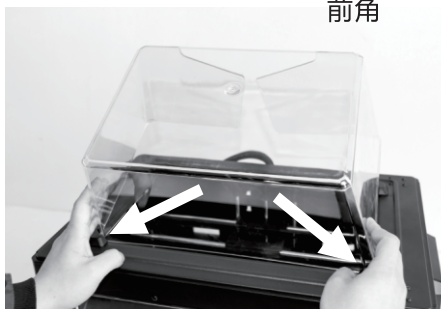
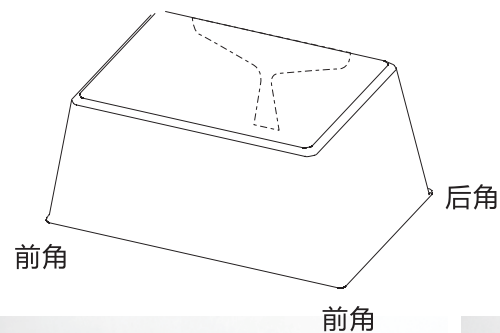

1. 先将顶罩的两个前角放入打印机顶部靠前的卡槽中。
2. 双手轻轻挤压顶罩后部，将两个后角也放入卡槽中。（取下顶罩的过程与此相反。）



YouTube



优酷自频道

Scan QR to Get More
After-Sales Support
扫描二维码获得更多售后支持



浙江闪铸三维科技有限公司
FLASHFORGE CORPORATION

After-Sales Service: support@ff3dp.com

售后专线 : support@ff3dp.com

Amazon.com orders only: 597891915@qq.com

Tel: +86 579 82273989 Web: www.flashforge.com Add: 2/F, No.518, Xianyuan Road, Jinhua, Zhejiang, China
电话 : 4008866023 官方网站 : www.sz3dp.com 地址 : 浙江省金华市仙源路518号