

SZ05-ZN/EN-A10

FINDER / 发现者

Quick Start Guide

≡ 快速启动指南 ≡

中文 P14



WARNING
注意事项

-
1. Hot! Avoid touching the heating nozzle in operation.
 2. Moving parts in printer may cause injury. Do not wear gloves or other sources of entanglement in operation.
1. 高温危险！打印机喷嘴在工作时会被加热，操作时请避免接触！
2. 可动部件可能会造成卷入挤压和切割伤害。操作机器时请不要佩带手套或缠绕物。
-

Unpacking

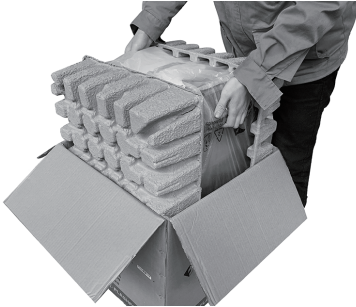

1. Open the box, grasp the external packing and then lift your Finder out of the box.



2. Remove the external packing and the plastic bag.



3. Remove the top insert.



4. You will see Quick Start Guide, After-sales Service Card, Power Cable, Filament Guide Tube and Tool Bag.

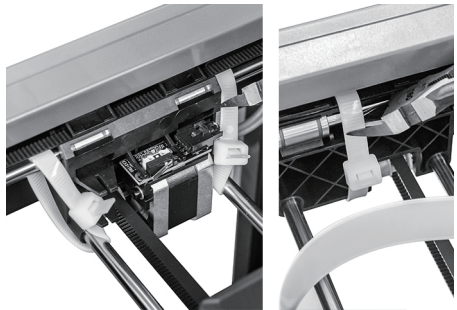

5. Use scissors to cut the four buckles that hold the rods in place.



6. Discard the blue tape that holds the flat cable in place. Be careful with the flat cable.



7. Remove the middle insert. A spool of filament is packed inside.



8. Hold on the platform, lift the build plate up with care.

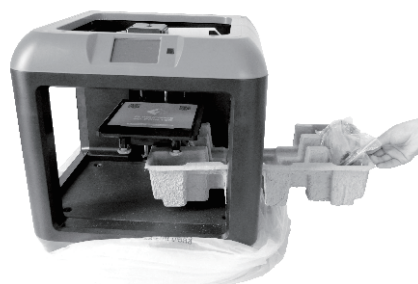

9. Remove the bottom insert. Power adapter, USB cable and solid glue are packed inside.



10. Remove the two yellow buckles that hold the Z-axis guide rods.

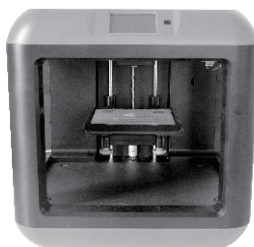

11. Congratulations! You've unpacked your printer. Please keep the kit and packing for future use.

Kit Contents

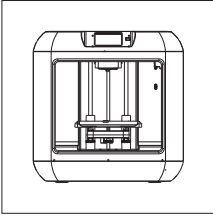

3D Printer

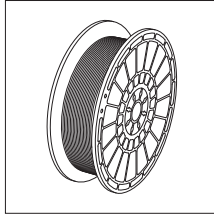

Filament Spool

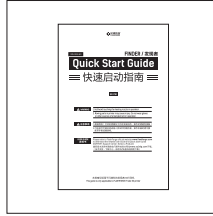

Quick Start Guide

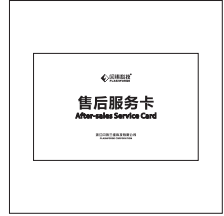

After-sales Service Card

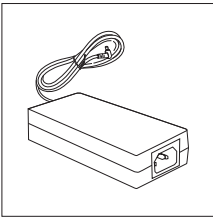

Power Adapter

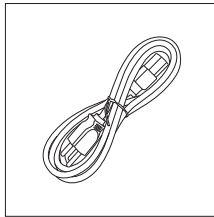

Power Cable

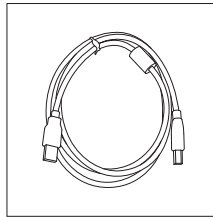

USB Cable

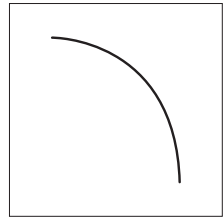

Filament Guide Tube

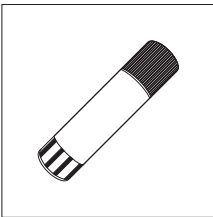

Solid Glue

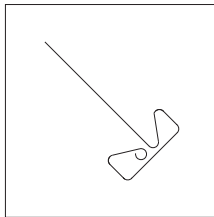

Unclogging Pin Tool

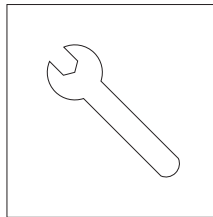

Wrench

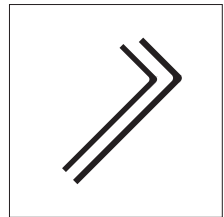

Allen Wrench

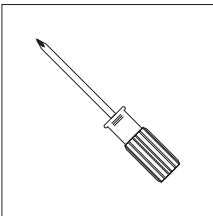

Screwdriver

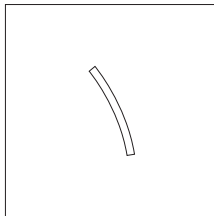

PTFE Tube

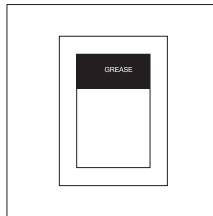

Grease

Getting to Know Your Finder

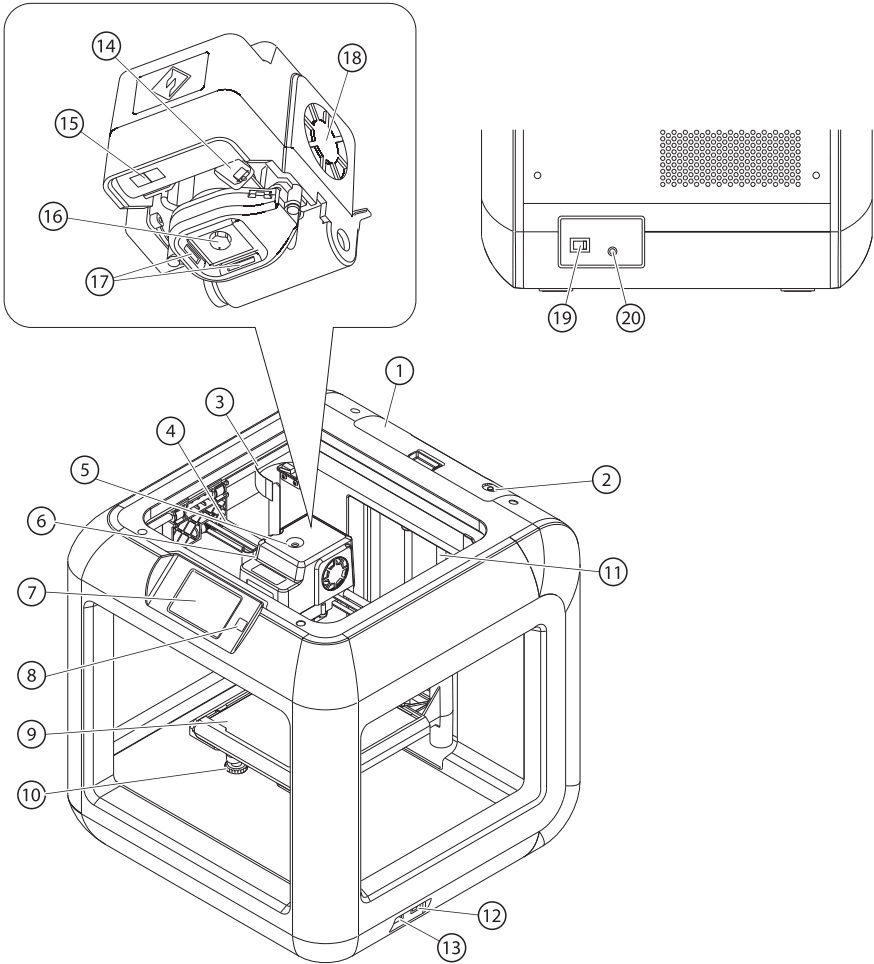

1. Filament Cartridge

2. Filament Outlet

3. Y-Axis Guide Rod

4. X-Axis Guide Rod

5. Filament Inlet

6. Spring Presser

7. Touch Screen

8. Touch Screen Button

9. Build Plate

10. Nut

11. Z-Axis Guide Rod

12. USB Cable Input

13. USB Stick Input

14. Servo

15. LED Light

16. Nozzle

17. Turbofan Baffle

18. Turbofan

19. Power Switch

20. Power Input

Hardware Assembly

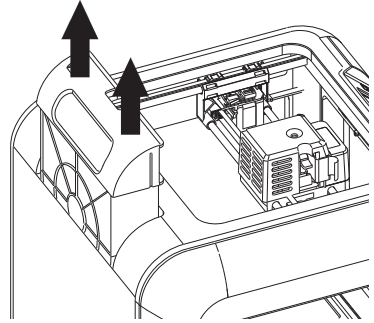
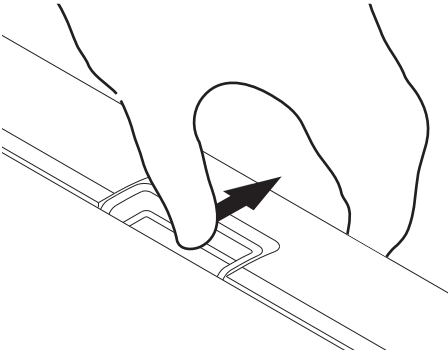

1. Filament cartridge is at the back of printer. Before taking out filament cartridge, please hold the clip on the top and take filament cartridge out.

! Please pay attention to loading direction!

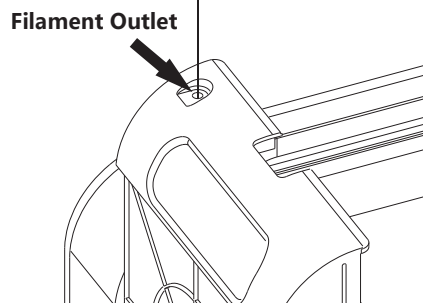
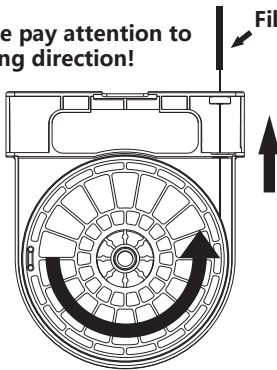

2. Take out filament, tear off vacuum packing and put it into filament cartridge. Put filament through filament outlet as the picture shown on the top left.

Attention: filament unwinding direction should keep pace with the picture, or causing cannot print property.

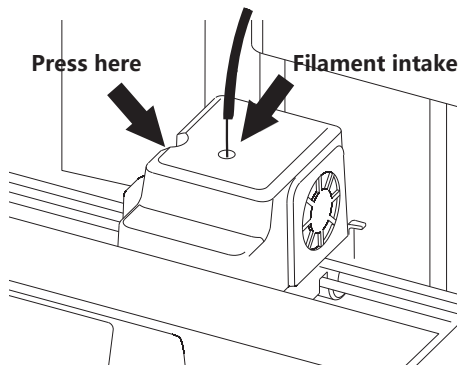
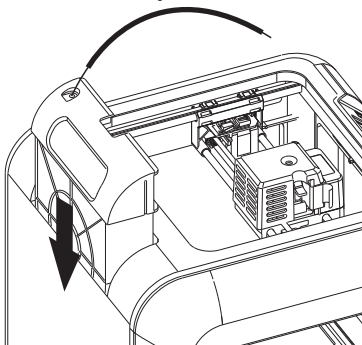

3. Hold clip on the top of filament cartridge, put filament cartridge back to the printer, and put filament through filament guide tube.
4. After filament goes through guide tube, press spring presser on the left side of extruder, and insert filament vertically into filament intake to the bottom.

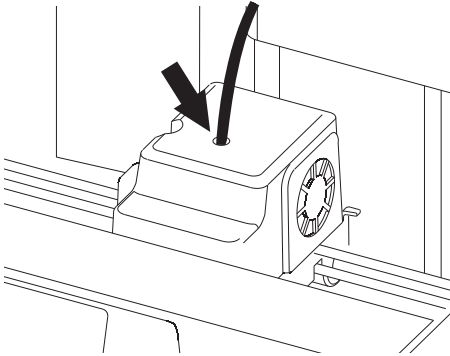

5. After inserting into filament intake, insert guidetube into extruder filament intake.

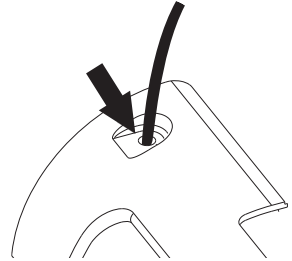

6. Finally put the other end of filament guidetube to filament outlet on the top of filament cartridge.

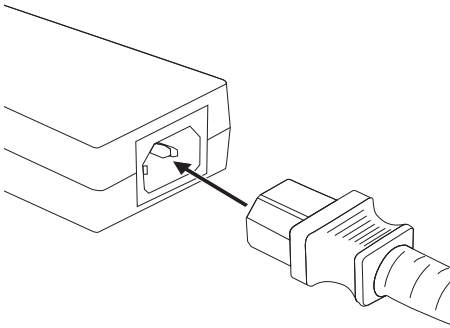

7. Connect the power adapter with the power cable.

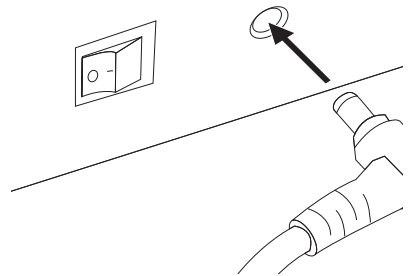

8. Insert the power supply into the power input on the back.

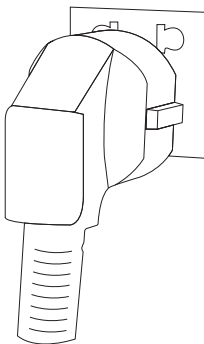

9. Plug the other end of power cable into socket, turn on the power switch.

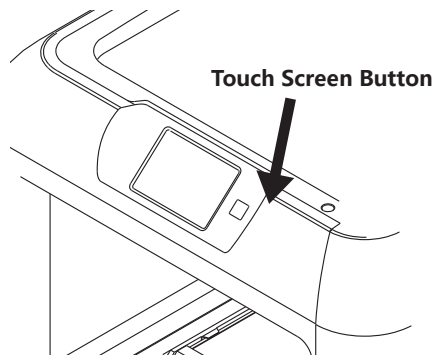

10. Press the touch screen button to turn on the printer.

Leveling Build Plate

How to change language

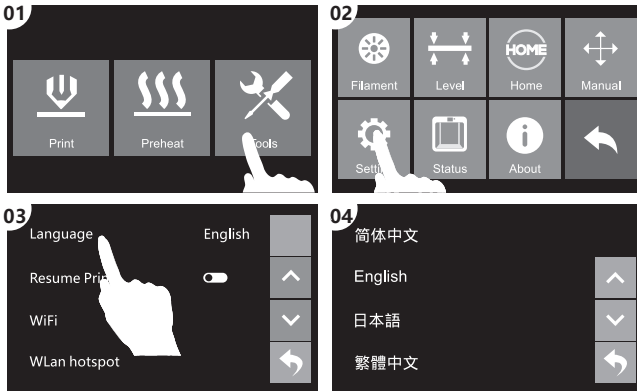

Before leveling, let's learn the function of nuts.

How to use the nuts

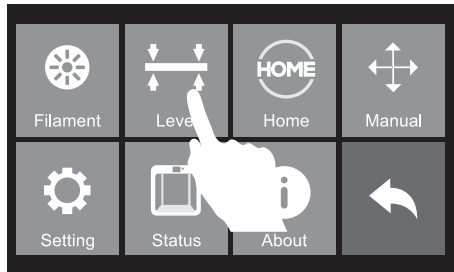
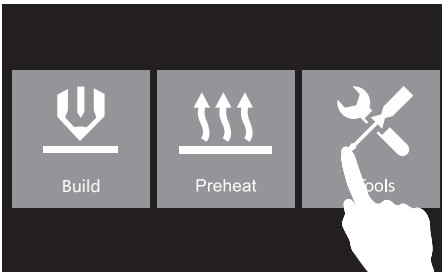
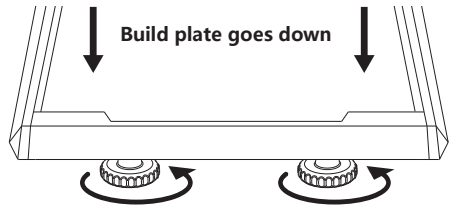
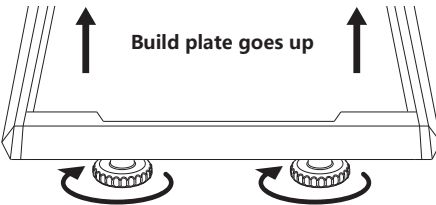

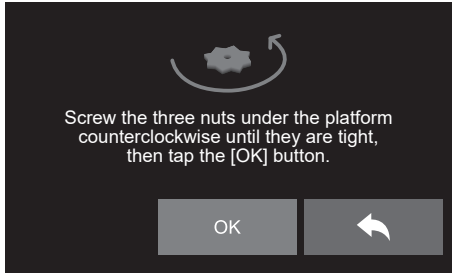
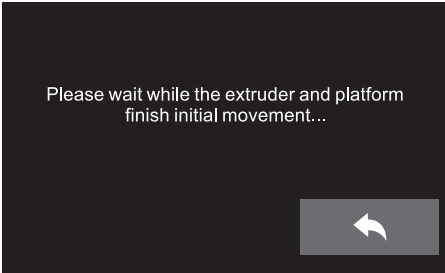

3. Please wait while the extruder and platform finish initial movements. Screw three nuts under the platform anticlockwise, then tap [OK] button.

Attention: three nuts may be tightened up before going out, please skip this step if you find three nuts have been tightened up, and continue to following steps

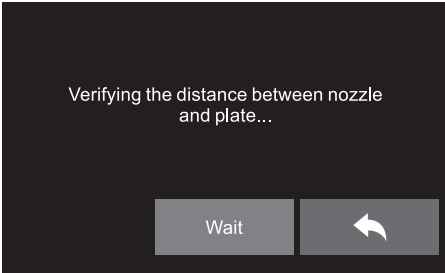

4. After tapping [OK] button, the extruder will move towards the first point and the plate will move up and down to verify the distance between nozzle and plate.

5. If the distance between the nozzle and plate is too large, rotate the three nuts underneath the platform clockwise for the same rounds until you hear a steady beep.

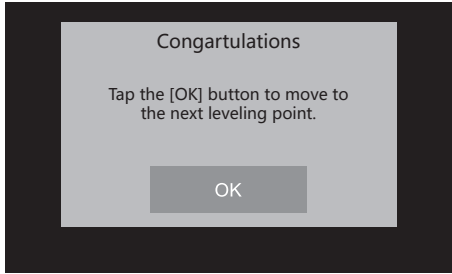
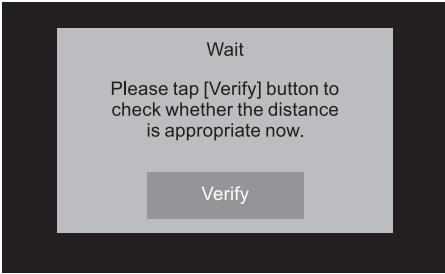

6. Tap the [Verify] button to check whether the distance is appropriate.

7. If the distance is appropriate, tap [ok] to next step. If the diastance still not appropriate, please follow the prompts on the touch screen to adjust till you see [ok].

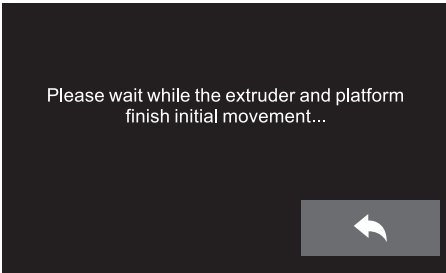

8. After first leveling point completed, start the other two leveling points.

Attention: when starting the second and the third leveling points, just need to adjust one corresponding nut under extruder.

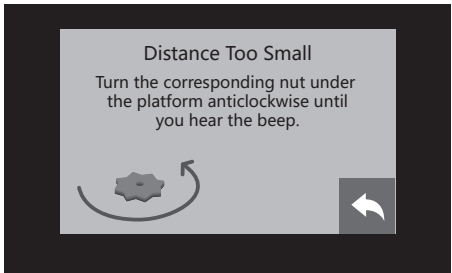
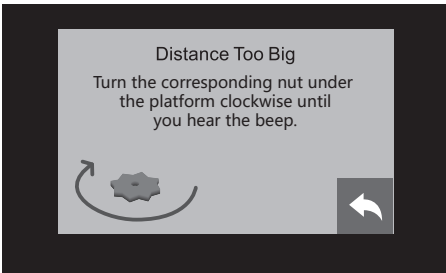

9. Follow the prompts on the touch screen to adjust the corresponding nut till you hear a steady beep.

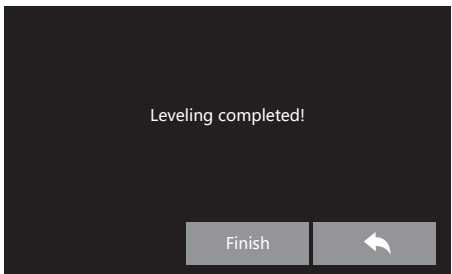
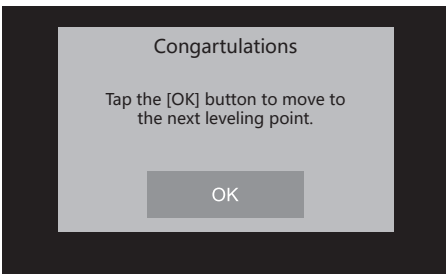

10. If the distance is appropriate, tap [ok] to next step. If the diastance still not appropriate, please follow the prompts on the touch screen to adjust till you see [ok].

11. Start the third leveling point according to the method of the second leveling point. After leveling completed, tap return arrow to go back to home screen.

Loading Filament

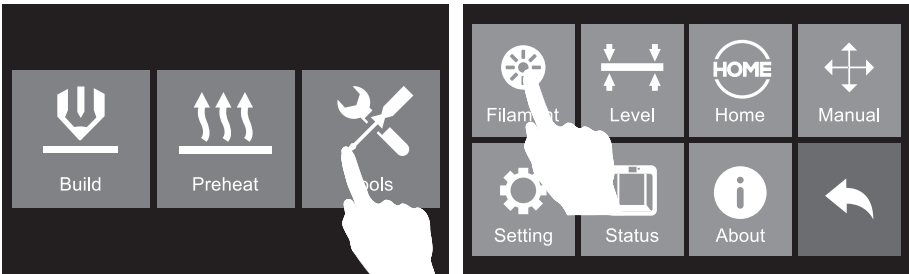

1. Tap [Tools] and then tap [Filament] and [Load] to load filament.

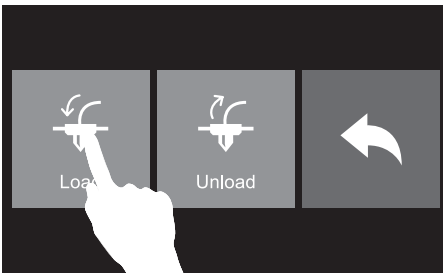

2. Tap [Load].

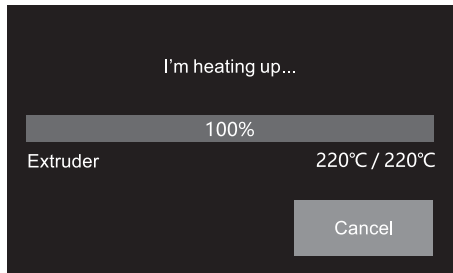

3. Extruder starts to heat.

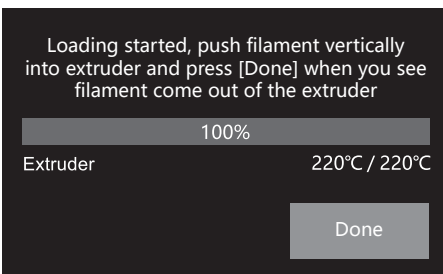

4. Once heated, filament will be drawn through the extruder. Continue extruding until the extruder provides a steady flow of filament.

Attention: If extruder can not unload in a long time, please check if you have inserted filament into the bottom of extruder.

First Print

Suggestions

1. Ensure that the build plate has been leveled before printing.
2. Ensure that the filament has been loaded in an appropriate approach.
3. Load the filament for a while to extrude all the melted filament you printed last time out of the extruder.
4. Please clean extruder before printing.
5. Do not leave the printer unattended during operation.

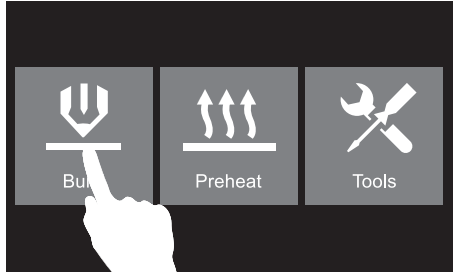

1. Tap [Build].

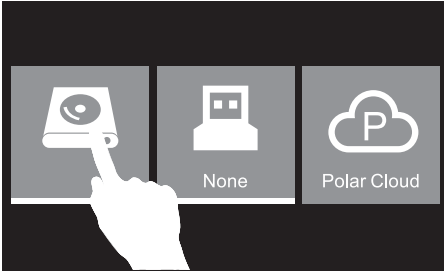

2. Tap [Memory Card] icon.

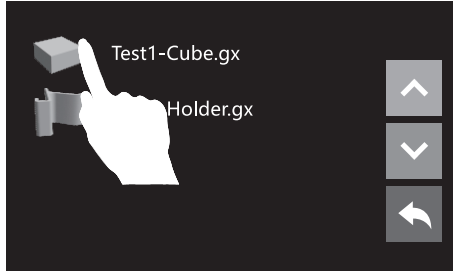

3. Tap [Test1-Cube.gx].

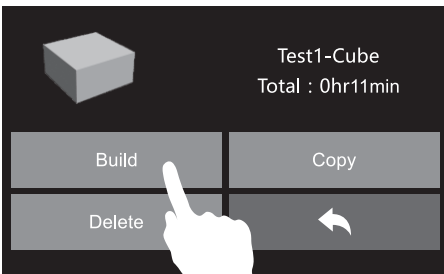

4. Tap [Build].

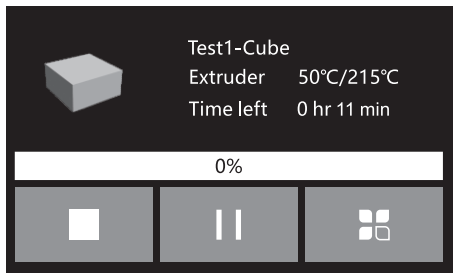

5. The extruder starts to heat, once heated, the printer will start to print.

Unloading Filament

Please follow steps below if you need to unload filament in daily use.

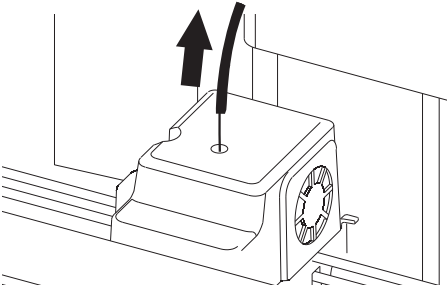

1. Pull filament guide tube out of filament intake, leave filament 10cm to pull filament easily.
2. Tap [Tools].

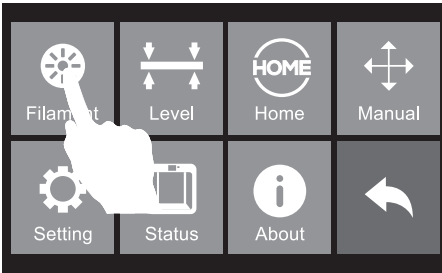
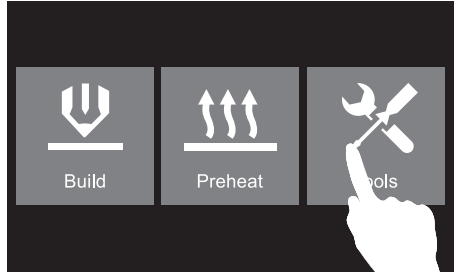

3. Tap [Filament].

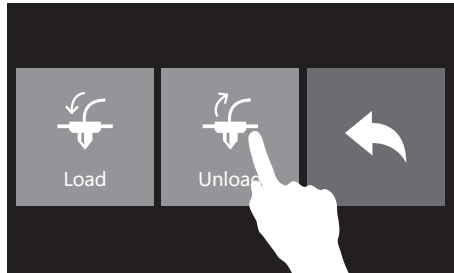

4. Tap [Unload].

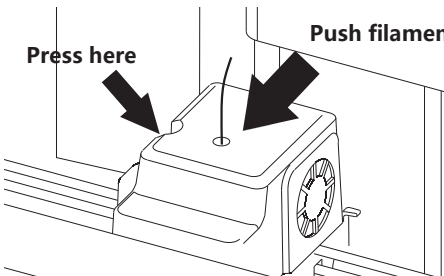
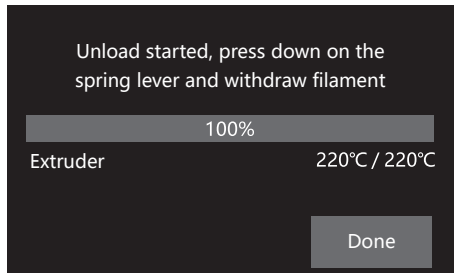
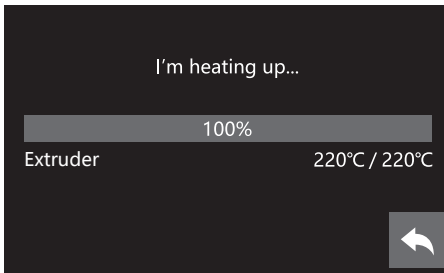

5. Extruder starts to heat. When heating to target temperature, press spring presser and push filament down through for 3 seconds until you see steady filament coming out from nozzle.

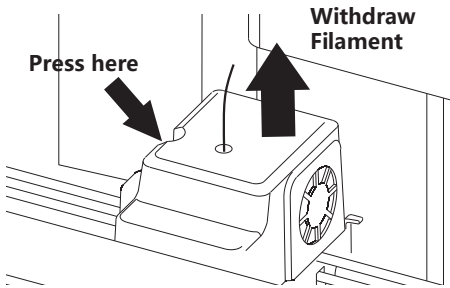

6. Then pull out vertically quickly and release spring presser. Tap [Finish], go back. Tap leftwards arrow go back to home screen.

开箱



1. 打开包装，取出打印机放置于工作台面。



2. 去除在运输中起保护作用的纸塑盒。



3. 去除包装袋。



4. 取出顶部的纸塑盒。



5. 在打印机顶部的纸塑盒中有一张快速启动指南、一根电源线、一份售后服务卡、一根导丝管和一个工具包。

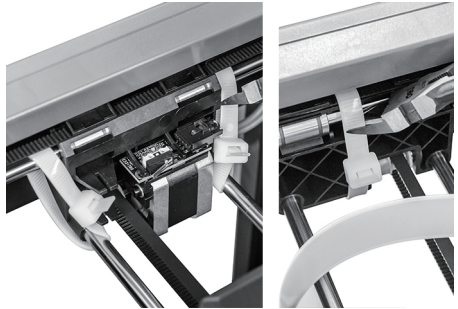

6. 剪断用来固定导轨的扎带，左右两侧一共四根。



7. 小心撕除固定喷头排线的无痕胶带。



8. 从侧面取出装有打印耗材的纸塑盒。



9. 用手托住打印平台，缓缓将其提升，以便于取出平台下方的纸塑盒。

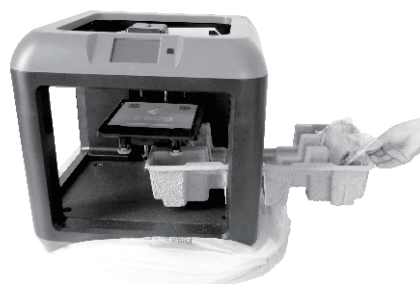

10. 从侧面取出放置有电源适配器、USB线和固体胶的纸塑盒。

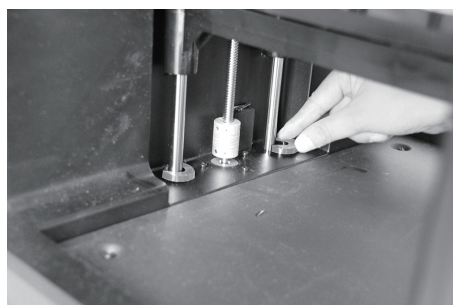

11. 去除Z轴导轨底部的两个黄色卡扣。

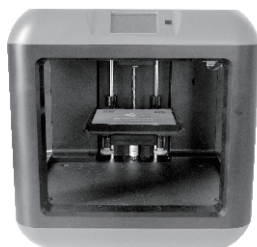

12. 至此Finder的开箱就完成了。请妥善保管配件及包装，以便于后续使用。

装箱物品

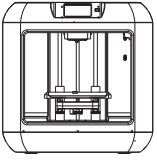

3D打印机

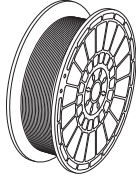

3D打印耗材



快速启动指南



售后服务卡

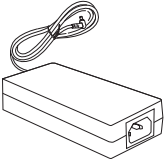

电源适配器



电源线

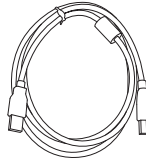

USB线



导丝管



固体胶

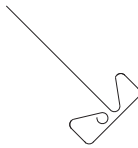

通针



冲压扳手



内六角扳手



十字螺丝刀



聚四氟管

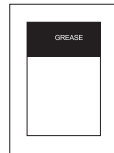

润滑脂

部件介绍

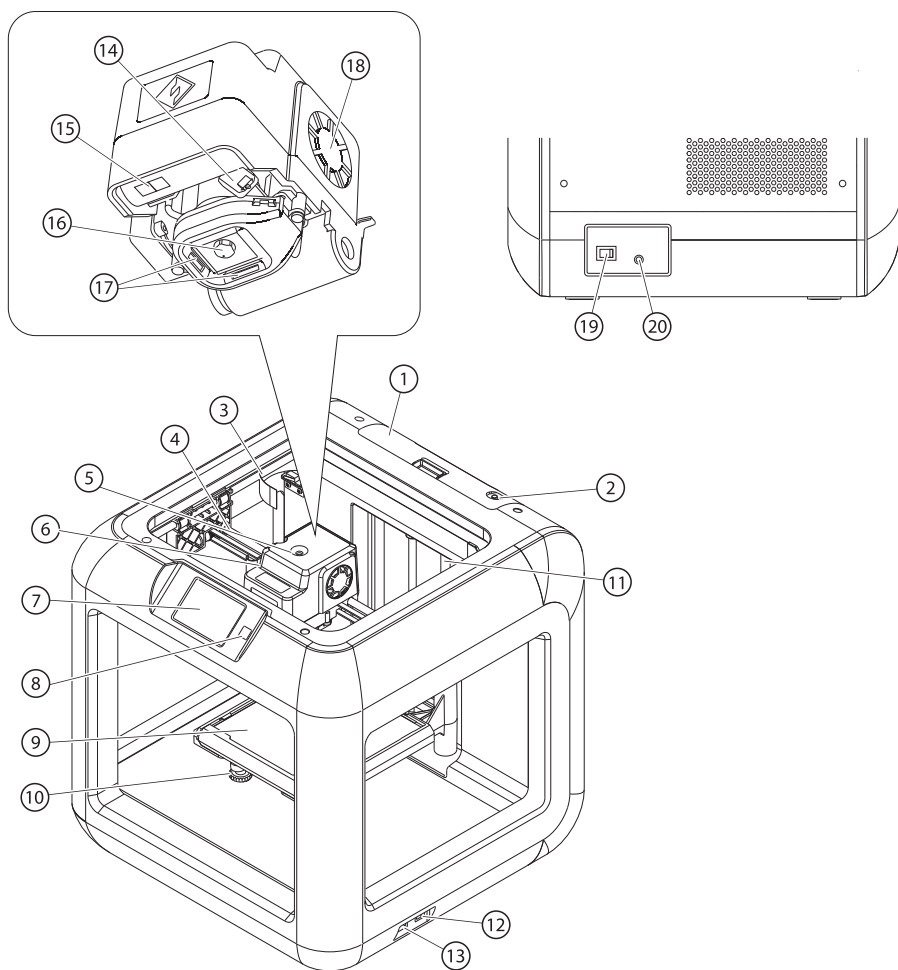

- | | | | | |
|----------|-------------|----------|----------|------------|
| 1. 丝盘盒 | 2. 丝盘盒出丝口 | 3. Y轴导轨 | 4. X轴导轨 | 5. 喷头进丝口 |
| 6. 进丝压板 | 7. 触摸屏 | 8. 触摸屏开关 | 9. 打印平台 | 10. 调平螺母 |
| 11. Z轴导轨 | 12. USB线插口 | 13. U盘插口 | 14. 调平舵机 | 15. 喷头灯 |
| 16. 喷嘴 | 17. 涡轮风扇出风口 | 18. 涡轮风扇 | 19. 电源开关 | 20. 电源输入端口 |

硬件安装

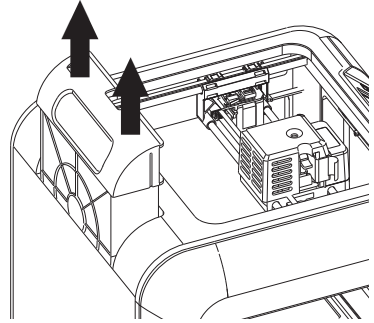
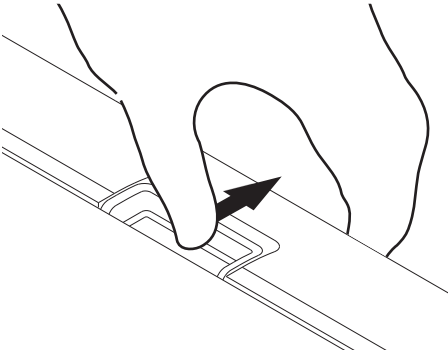

1. 发现者3D打印机的丝盘盒位于打印机背部。在取出丝盘盒之前，请捏住顶部的卡扣，然后向上取出丝盘盒。

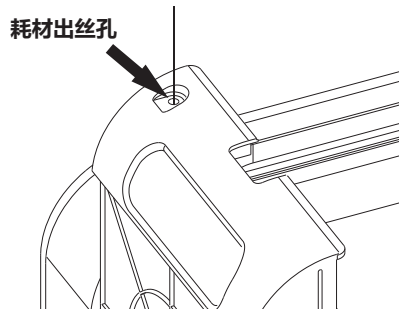
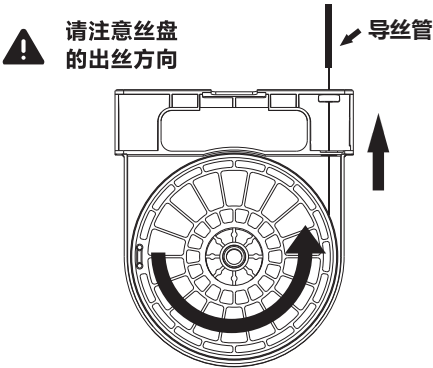

2. 取出耗材，去除真空包装后放入丝盘盒。按上方左侧图片所示的方向，将耗材穿过耗材出丝孔。
注意：请确保耗材的出丝方向与图片一致，否则可能导致无法正常打印。

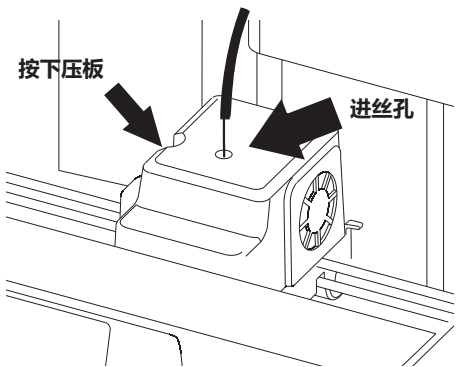
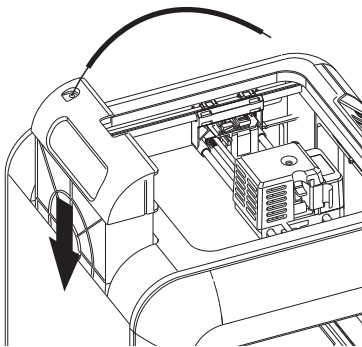

3. 捏住丝盘盒顶部的卡扣，把丝盘盒放回打印机，然后将耗材穿过导丝管。
4. 耗材穿过导丝管后，按下喷头左侧的压板，然后将耗材垂直插入喷头进丝孔中，直到耗材无法继续插入。

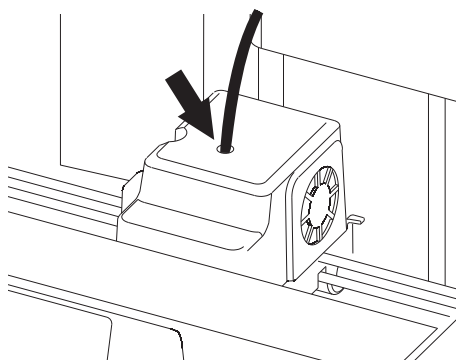

5. 耗材插入进丝孔后，再将导丝管插入喷头进丝孔固定。

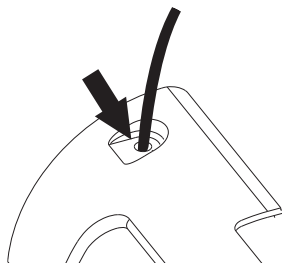

6. 最后将导丝管的另一头插入丝盘盒顶部的出丝孔固定。

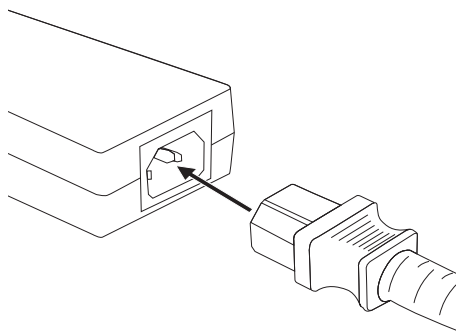

7. 连接电源适配器和电源线。

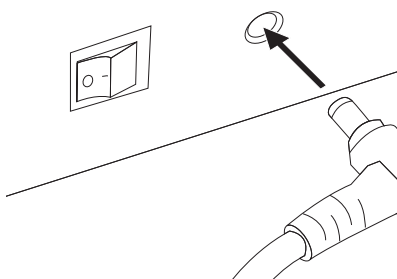

8. 将电源适配器输出端插入打印机背部的电源输入端口。

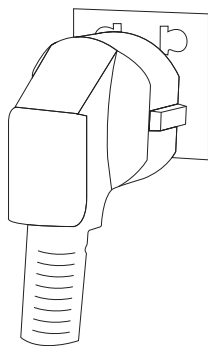

9. 将电源线的另一头插入电源插座，打开打印机背部的电源开关。



10. 最后按下触摸屏右侧的开关开机。

调平

将液晶屏语言设置为中文

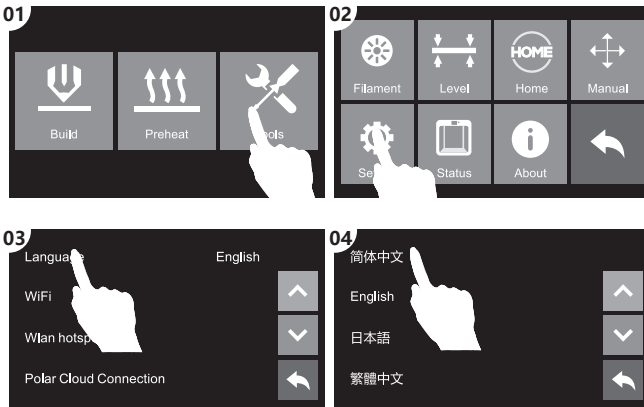

1. 发现者在出厂时默认操作语言为英文，请根据下列步骤切换至中文：在触摸屏上依次点击[Tools]、[Setting]、[Language]、[简体中文]。
2. 语言设置完成后，点击返回键返回主界面，准备开始调平。在开始调平之前，让我们先了解一下调平螺母的作用。

如何通过调平螺母调节打印平台

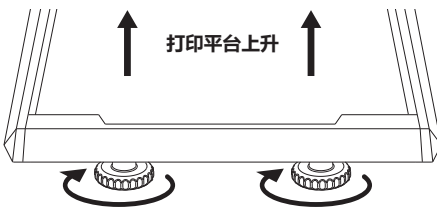

顺时针旋转螺母

打印平台上升，喷嘴与平台之间的间距变小

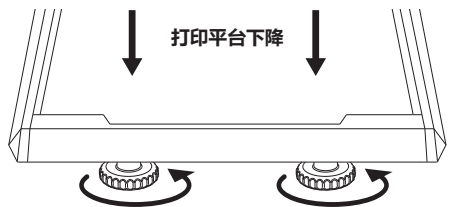

逆时针旋转螺母

打印平台下降，喷嘴与平台之间的间距变大



1. 在触摸屏上点击[工具]。



2. 点击[调平]。

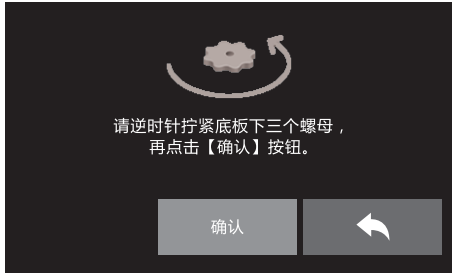
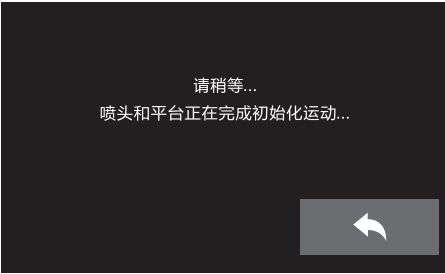

3. 待初始化运动完成后逆时针拧紧打印平台下的三颗螺母，点击[确认]。

请注意：在出厂前的测试中，三颗螺母可能已经被拧紧，如发现螺母已处于拧紧状态，请跳过拧紧螺母这一步骤，继续进行后续操作。

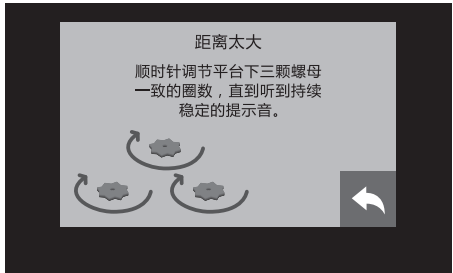
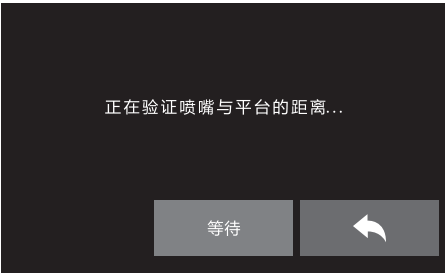

4. 点击[确认]后，喷头开始移向第一个点，开始验证喷嘴与平台之间的距离。

5. 根据触摸屏提示，顺时针调节平台下的三颗螺母一致的圈数，直到听到持续稳定的提示声。

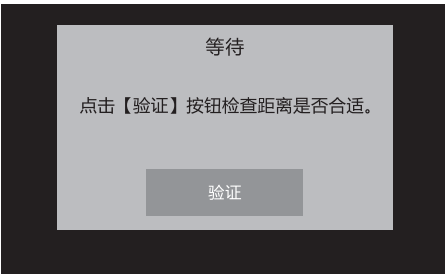

6. 听到持续稳定的提示声之后点击[验证]进行确认。

7. 若距离合适，点击[确认]进行第二点调平。若距离依然不合适，请继续按触摸屏提示操作，直至调平成功。

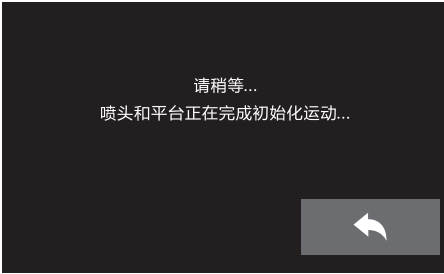

8. 在第一点调平完成后，开始剩余两点调平。

请注意：在第二点和第三点调平时，只需要调节喷头下方对应的一颗螺母即可。

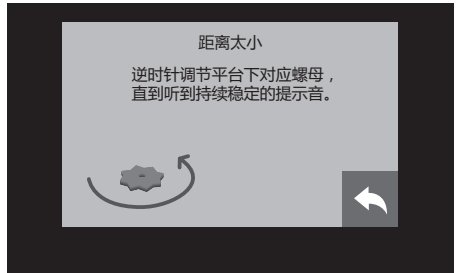
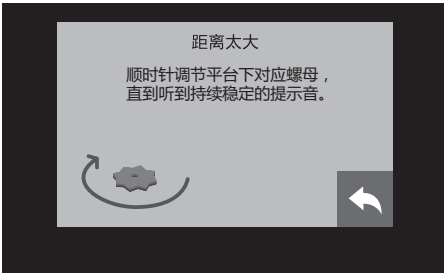

9. 根据触摸屏提示的方向，调节平台下对应的螺母，直到听到持续稳定的提示声。



10. 若距离合适，点击【确认】进行第三点调平。
若距离依然不合适，请继续按触摸屏提示操作，直至调平成功。

11. 第三点调平按照第二点调平的方法。
三个点调平完成后，按返回键回到首界面。

填装耗材



1. 在首界面点击[工具]。



2. 点击[换丝]。

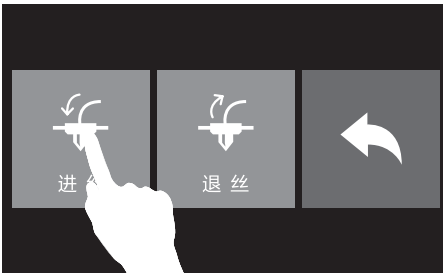

3. 在点击[进丝]。

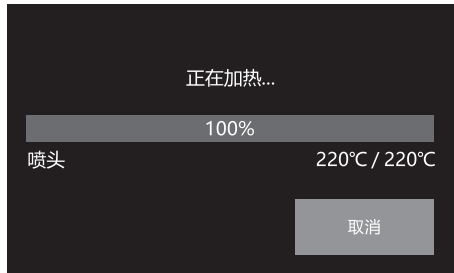

4. 喷头会自动开始加热。

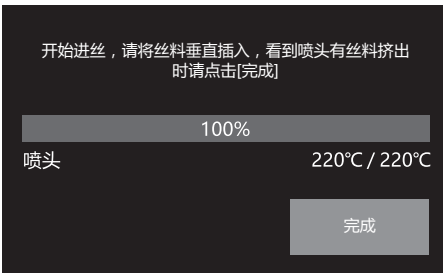

5. 喷头加热到预定的温度后会自动开始进丝。当喷嘴开始出丝时请勿立即停止进丝，直到耗材均匀出丝为止。点击[完成]，返回主界面。

注意：若长时间喷头未出丝，请检查填装耗材时是否正确将耗材插入喷头底部。

首次打印

打印建议

1. 打印开始前请确保打印机已经过调平；
2. 打印开始前请确保耗材安装正确，没有打结或卡住；
3. 喷头内可能残留少量耗材，请进丝一段时间，确保上一次打印的耗材已全部挤出；
4. 打印开始前请将喷头耗材清理干净；
5. 不可以在长时间无人看守的情况下使用3D打印机；

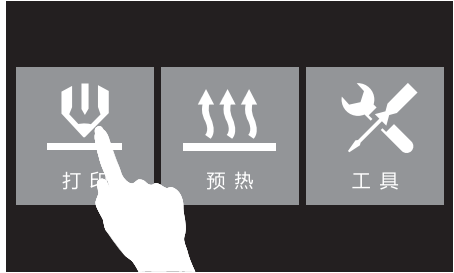

1. 在首界面点击[打印]。



2. 点击[打印机内部存储]。

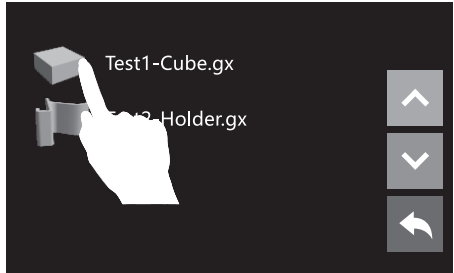

3. 选择[Test-Cube.gx]。



4. 点击[打印]。

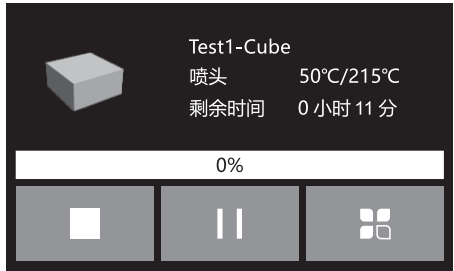

5. 喷头开始加热，加热完成后开始打印。

退丝操作

在日常使用中，如果需要更换耗材，请按下列步骤操作。

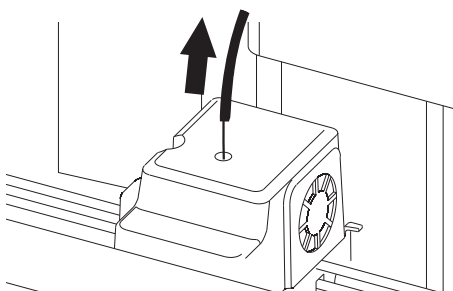

1. 将导丝管从喷头进丝口拔出，露出10厘米耗材，方便拔出耗材。



2. 在触摸屏上点击[工具]。



3. 点击[换丝]。

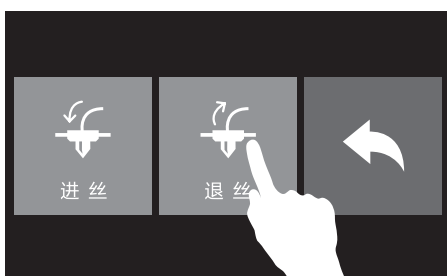

4. 点击[退丝]。

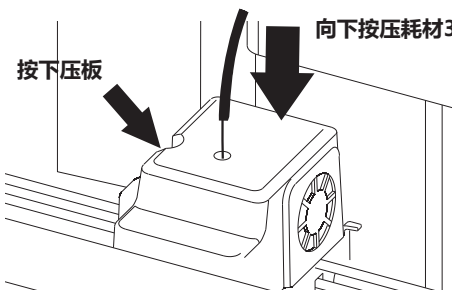
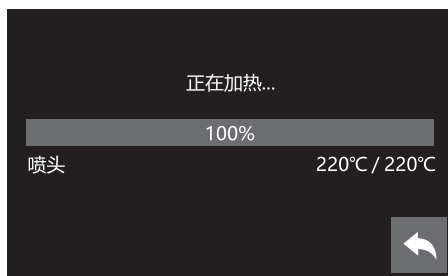

5. 喷头开始加热。当喷头加热到预定温度后，按下喷头侧边的压板，同时向下按压耗材3秒，直到看到耗材从喷嘴处被挤出。

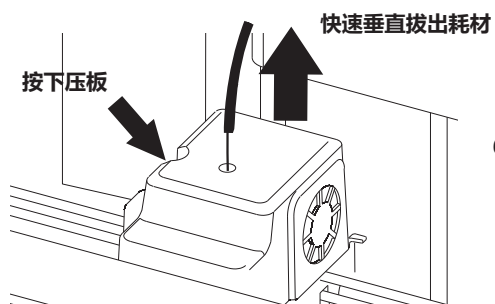

6. 快速垂直拔出耗材。点[完成]返回上一级，点返回键返回主界面。



YouTube



优酷自频道

Scan QR to Get More
After-Sales Support
扫描二维码获得更多售后支持



浙江闪铸三维科技有限公司
FLASHFORGE CORPORATION

After-Sales Service: support@flashforge.com

售后专线 : support@flashforge.com

Amazon.com orders only: 597891915@qq.com

Tel: +86 579 82273989 Web: www.flashforge.com Add: 2/F, No.518, Xianyuan Road, Jinhua, Zhejiang, China
电话 : 4008866023 官方网站 : www.sz3dp.com 地址 : 浙江省金华市仙源路518号